



CattronControl™

CT24-9, CT24-9-ASO, CT24-17 and CT24-32

Machine Control Units (MCUs)

User Manual

9M02-7608-A001-EN



CONNECT. CONTROL. PROTECT.

Revision History

VERSION	DATE	NOTES
1.0	05/2016	Initial Release
2.0	09/2019	Rebranded to Cattron Added CT24-9-ASO
3.0	03/2020	Clarified detail on CT24-9-ASO Added detail for configuration installation, performance level, specifications.
3.1	04/2020	Minor corrections and clarifications ECO-20-0092
3.2	03/2021	Chinese translation created ECO-20-0464
3.3	06/2022	Linked sub languages

Any information furnished by Cattron™ and its agents is believed to be accurate and reliable. All specifications are subject to change without notice. Responsibility for the use and application of Cattron products rests with the end user since Cattron and its agents cannot be aware of all potential uses. Cattron makes no warranties as to non-infringement nor as to the fitness, merchantability, or sustainability of any Cattron products for any specific or general uses. Cattron Holdings, Inc., or any of its affiliates or agents shall not be liable for incidental or consequential damages of any kind. All Cattron products are sold pursuant to the Terms and Conditions of Sale, a copy of which will be furnished upon request. When used as a tradename herein, Cattron means Cattron Holdings, Inc. or one or more subsidiaries of Cattron Holdings, Inc. Cattron™, corresponding logos, and other marks are trademarks or registered trademarks of Cattron Holdings, Inc. Other marks may be the property of third parties. Nothing herein

Contents

1. Introduction.....	7
1.2 Terminology	7
2. Warnings and Cautions	8
2.1 General Safety Information	10
2.2 Intended Use.....	11
2.3 Improper Use	11
2.4 Safety Instructions for Assembly/Disassembly	11
2.5 Operation of OCUs and MCUs with Identical System Address.....	11
3. General	12
3.1 Radio Transmission	12
3.1.1 Continuous Transmission.....	12
3.1.2 Radio Interference.....	12
3.2 Telegram Security	12
3.2.1 Frame Type.....	12
3.2.2 System Address	12
3.2.3 CRC	12
3.2.4 Frame Counter	13
3.3 System Parameters.....	13
4. MCU Overview	14
4.1 General	14
4.2 Antenna.....	15
4.3 CT24-9	16
4.4 CT24-9-ASO	17
4.5 CT24-17	18
4.6 CT24-32	19
4.7 Status LEDs	20
4.8 Optional 9-36 VDC Input MCUs.....	21
5. Installation.....	22
5.1 General	22
5.2 Mounting	22
5.2.1 Choosing a Mounting Location.....	22
5.3 Interface	26
5.4 Relay Rating.....	26
5.5 Interface Wiring.....	26
5.6 Safety Critical Interfaces	26
5.7 Power and Control Cables Interface	26



5.8	Determination of Correct Control Circuit Wire Gauge	27
5.8.1	For High Duty Cycle Applications.....	29
5.8.2	For Low Duty Cycle Applications	29
5.9	Examples of Wire Sizing	30
5.9.1	Low Duty Application (Typical Crane)	30
5.9.2	High Duty Application (Crane with Multi Select or Machine).....	30
5.9.3	High Duty Maximum Current Application	30
5.10	Connection of Wires to Interface Connectors	30
5.10.1	Interface Connectors.....	30
5.10.2	Overview	30
5.10.3	Spring Clamp Type Inserting a Wire	31
5.10.4	Spring Clamp Type Removing a Wire.....	31
5.10.5	Terminal Specifications.....	31
5.10.6	Ferrule Types.....	31
6.	MCU Connections	34
6.1	CT24-9	34
6.2	CT24-9-ASO (AC version)	35
6.2.1	Replacing a CT24-9 with a CT24-9-ASO	35
6.3	CT24-9-ASO (DC Version).....	36
6.3.1	Replacing a CT24-9 with a CT24-9-ASO	36
6.4	CT24-17	37
6.5	CT24-32	38
6.6	Conduit.....	39
6.7	The Controlled Machine	40
6.8	Control Power	40
6.9	Fuses	40
6.10	Relay Outputs	40
6.11	Mainline Circuit.....	41
6.12	Manual / Remote Transfer	44
6.13	Main Circuit Breaker.....	45
6.14	Control Circuit Power	45
6.15	Antenna.....	45
7.	Optional System Features.....	47
7.1	OCU Automatic Turn-Off.....	47
7.2	System Startup Options	47
7.2.1	Normal Start-up.....	47
7.2.2	OCU Roaming.....	47
7.3	Motion Enable Features	47



7.3.1	Push To Operate (PTO)	47
7.3.2	Push To Enable (PTE)	48
7.3.3	Double Jog Enable (DJE) (LRC OCUs only).....	49
7.3.4	Vigilance.....	49
7.4	IR Link	50
7.4.1	Feature and Benefits	50
7.4.2	Features Options.....	50
7.5	RF Range Control	52
7.5.1	Feature and Benefits	52
7.5.2	Feature Options	53
7.5.3	Operating Modes.....	53
7.5.4	Notes on the Differences between IR and RF Close Start.....	54
7.6	Delayed Shutoff (LRC OCUs only).....	54
7.7	User Authorization.....	55
7.8	Multi Address Capability (MAC)	55
7.8.1	REQUEST Function	56
7.8.2	RELEASE Function.....	56
7.9	Sub Address Capability.....	56
7.9.1	T-SAC TransKeys	56
7.9.2	B-SAC	56
7.10	TDMA	57
7.11	Frequency Scanning	57
7.12	SymmetryLock™	57
7.12.1	Key Value Statements	58
7.13	Multi-MCU Talkback.....	58
7.14	Talkback and LCD Display Resolution.....	58
8.	Requirements to Achieve PLd within a ‘System’	59
9.	Functional Safety Compliance Data CT24-9-ASO	60
9.1	Mission Time	60
9.2	Service Time	60
9.3	MTTFd Scoring Table	60
9.4	Diagnostic Coverage (DC) Scoring Table	60
9.5	CC Failure	60
9.6	B10d Values Used	60
9.7	SRP/CS Performance Levels.....	61
9.8	Equipment PL Summary	61
10.	MCU Error Codes	62
11.	CE Declaration of Conformity	63



12. Technical Specifications 64



1. Introduction

This manual includes general information concerning the operation of the radio remote Machine Control Unit (MCU) series CT24. The information is of a general nature and does not include system-specific data. System-specific data is provided in the technical documentation accompanying the delivery of the system.

For information pertaining to the matching Operator Control Unit (OCU), please refer to the separate OCU user manual.

1.2 Terminology

The following represents important acronyms and long form names used in this document:

- OCU – Operator Control Unit, historically referred to as a *transmitter*
- MCU – Machine Control Unit, historically referred to as a *receiver*
- ASO – Automatic Safety Override; in this context, a fully automatic system shutdown made possible by the use of safety relays on motion output relays to detect a welded or closed contact when it should be open
- N/O – SPST Normally Open, Form A
- N/C – SPDT Normally Closed, Form C (BBM)



2. Warnings and Cautions

WARNING and CAUTION statements are strategically placed throughout all text prior to operating or maintenance procedures, practices or conditions considered essential to the protection of personnel (WARNING), or equipment and property (CAUTION). A WARNING and CAUTION applies each time the related step repeats. Before starting any task, review and understand the WARNINGS or CAUTIONS included in the text. All WARNINGS and CAUTIONS appearing in this manual are included below.

	WARNING
	<p>ALL EQUIPMENT MUST HAVE A MAINLINE (ML) CONTACTOR INSTALLED AND ALL TRACKED EQUIPMENT (I.E., CRANES) MUST HAVE A BRAKE INSTALLED. THE REMOTE CONTROL SAFETY RELAYS MUST BE CONNECTED TO THE MAINLINE SO THAT STOP COMMANDS WILL DE-ENERGIZE THE MAINLINE CONTACTOR AND SET THE EQUIPMENT BRAKE. FAILURE TO COMPLY WITH THE ABOVE WARNINGS MAY RESULT IN SERIOUS INJURY OR DEATH TO PERSONNEL AND DAMAGE TO EQUIPMENT.</p>

	WARNING
	<p>MORE THAN ONE REMOTE CONTROL SYSTEM MAY BE USED AT, AROUND, OR NEARBY YOUR OPERATING FACILITY. THEREFORE, BEFORE INSERTING A 'TRANSKEY', YOU MUST INSURE THE CORRECT CODED 'TRANSKEY' IS SELECTED FOR THE DESIRED EQUIPMENT TO BE OPERATED. IF THE WRONG 'TRANSKEY' IS INSERTED, OTHER REMOTE CONTROLLED EQUIPMENT LOCATED AT, AROUND, OR NEARBY YOUR FACILITY MAY BECOME OPERATIONAL. FAILURE TO COMPLY WITH THE ABOVE WARNINGS MAY RESULT IN UNINTENDED OPERATION OF REMOTE CONTROLLED EQUIPMENT WHICH IN TURN COULD RESULT IN SERIOUS INJURY OR DEATH TO PERSONNEL AND DAMAGE TO EQUIPMENT.</p>

	WARNING
	<p>BEFORE ATTEMPTING TO USE THE REMOTE CONTROL SYSTEM, VERIFY THE TARGET CRANE OR MACHINE YOU WISH TO OPERATE IS UNDER THE DIRECT COMMAND OF YOUR OCU. THIS IS ACCOMPLISHED BY OPERATING A NON-MOTION OCU FUNCTION SUCH AS THE HORN AND OBSERVING THAT THE HORN SOUNDS ON THE TARGETED CRANE OR MACHINE. FAILURE TO IMPLEMENT THE ABOVE MAY RESULT IN SERIOUS INJURY OR DEATH TO PERSONNEL AND DAMAGE TO EQUIPMENT.</p>



	WARNING
	<p>UNLESS SPECIFIED, REMOTE CONTROL SYSTEMS ARE NOT DESIGNED TO INTERFACE DIRECTLY TO SAFETY CRITICAL BISTABLE MAINTAINED FUNCTIONS (i.e., magnetic circuits, vacuum circuits, grab, pump motors, fire suppression, etc.).</p> <p>A PROPER INTERFACE TO SAFETY CRITICAL BISTABLE MAINTAINED FUNCTIONS SHALL BE INSTALLED, IDEALLY USING A RELAY INTERFACE UNIT.</p> <p>SHOULD CATTRON SYSTEMS BE INADVERTENTLY CONFIGURED TO INTERFACE DIRECTLY WITH SAFETY CRITICAL BISTABLE MAINTAINED FUNCTIONS AT YOUR OPERATING FACILITY, DAMAGE TO EQUIPMENT, SERIOUS INJURY OR DEATH TO PERSONNEL MAY RESULT.</p> <p>IT MUST BE FULLY UNDERSTOOD THAT CATTRON WILL NOT BE HELD LIABLE FOR PERSONAL INJURY, DEATH, EQUIPMENT OR PROPERTY DAMAGE WHICH MAY ARISE FROM IMPROPER CONFIGURATION OF YOUR REMOTE CONTROL SYSTEM.</p>

	WARNING
	<p>THE USE OF UNAPPROVED COMPONENTS OR ACCESSORIES IN THE SYSTEMS SOLD BY CATTRON AND ITS SUBSIDIARIES IS STRICTLY PROHIBITED. UNAPPROVED COMPONENTS ARE DEFINED AS ANY COMPONENT NOT INSPECTED AND SOLD BY CATTRON. THIS ALSO INCLUDES ANY COMPONENT MODIFIED FROM ITS INTENDED USE AND/OR ANY COMPONENT EXHIBITING OBSERVABLE DAMAGE OR DEFECT.</p> <p>USE OF NON-CONFORMING PARTS, ASSEMBLIES AND ACCESSORIES MAY LEAD TO INJURY OR DEATH.</p>

	WARNING
	<p>ONLY PERSONEL TRAINED AND AUTHORIZED BY CATTRON, OR PERSONEL UNDER THE DIRECT GUIDANCE OF CATTRON TECHNICAL STAFF AND WHILE USING THE APROPRIATE TOOLS, ARE AUTHORIZED TO CARRY OUT BOARD LEVEL MAINTENANCE OF THE CT24 MCU.</p> <p>COMPONENT LEVEL REPAIR BY PERSONEL OTHER THAN CATTRON TECHNICAL STAFF IS STRICTLY FORBIDDEN.</p> <p>USE OF NON-CONFORMING PARTS, ASSEMBLIES AND ACCESSORIES MAY LEAD TO INJURY OR DEATH.</p>

	WARNING
	<p>THE MCU MAY BE CONNECTED TO, AND SWITCHING MULTIPLE POWER SOURCES, ENSURE THAT THE MCU IS COMPLETELY ISOLATED BEFORE CONNECTING OR DISCONNECTING ANY WIRING.</p> <p>FAILURE TO COMPLY WITH THE ABOVE WARNINGS MAY RESULT IN SERIOUS INJURY OR DEATH TO PERSONNEL AND DAMAGE TO EQUIPMENT.</p>



	WARNING
	THE REMOTE CONTROL SYSTEM YOU HAVE PURCHASED IS DESIGNED TO STOP IN A SAFE MODE UNDER A VARIETY OF CONDITIONS. SOME EXAMPLES OF THESE CONDITIONS ARE EXCESSIVE RADIO SIGNAL INTERFERENCE, LOSS OF BATTERY AND/OR ELECTRICAL POWER, FAILURE OF CERTAIN COMPONENTS, OPERATION BEYOND SIGNAL RANGE AND OTHERS. ALTHOUGH CATTRON AND ITS SUBSIDIARIES DO NOT SPECIFY THE POSITION OF THE OPERATOR WHEN CONTROLLING THE EQUIPMENT, WE ARE AWARE THAT SOME USERS ARE INSTRUCTED AND TRAINED BY THEIR EMPLOYER TO RIDE THE EQUIPMENT IN A SAFE MANNER. IT IS IMPERATIVE THAT YOU ARE PREPARED FOR AN UNPLANNED STOP OF THE EQUIPMENT AT ANY TIME AND DO NOT PLACE YOURSELF OR OTHERS IN A POSITION WHERE THIS SITUATION MAY CAUSE YOU TO FALL FROM THE EQUIPMENT. FAILURE TO USE CAUTION MAY LEAD TO INJURY OR DEATH.

2.1 General Safety Information

- Persons under the influence of drugs, alcohol and/or other medicine that impairs reaction may not assemble, disassemble, install, put into operation, repair or operate the product.
- All conversions and modifications of an installation or system must conform to the relevant safety requirements. Only qualified, trained, authorized personnel may perform work on the equipment, in accordance with the relevant safety requirements.
- In the event of malfunction and/or visible defects or irregularities, the product must be stopped, switched off, and the relevant master switches also switched off.

	WARNING
	Observe the statutory regulations and directives applicable for the intended purpose, e.g.: <ul style="list-style-type: none">• Accident prevention regulations• Safety rules and directives• Standards• Generally applicable statutory and other binding regulations for accident prevention and environmental protection, and general safety and health requirements.

- Keep the operating manual permanently accessible at the place of product use.
- The personnel assigned to work on/with the product must have read and understood this operating manual and the safety instructions.
- The safety instructions must, if necessary, be supplemented by the user with instructions concerning the work organization, work sequences, qualified personnel, etc.
- All repairs made during the warranty period must be carried out by the manufacturer or appointed authorized service center; failure to comply will invalidate the warranty.
- Only trained personnel may perform maintenance and repair on the product.
- All repairs made should be carried out in a suitably clean static-safe environment, free from contaminants such as metal filings, water, oil, etc.
- It is the user's responsibility to ensure that the product always operates in good condition and that all applicable safety requirements and regulations are observed.
- Product modifications may not be carried out without the consent of the manufacturer.
- Original spare parts from the manufacturer must be used.
- Carry out periodic inspections and/or maintenance either required by law or prescribed in the user manual within the required intervals.



2.2 Intended Use

The product must only be used in good condition, by instructed personnel, and subject to compliance with all applicable safety and accident prevention regulations. Use only for the intended purpose and according to the instructions contained within this user manual.

2.3 Improper Use

Ensure compliance with equipment ratings and operate only as intended, in particular:

- Only authorized and trained personnel should open the MCU cover and install/maintain
- Ensure all supplies to the equipment are isolated before installation/maintenance
- Check that power supply voltage/frequency data is correct
- Do not misuse or exceed operating specifications
- Ensure daily and periodic maintenance routines are observed

	CAUTION
	Damage to the device: The unit is rated at IP65. For environments harsher than this, use an appropriate secondary enclosure. Neglecting the above can result in danger for life and limb and/or cause physical damage to the product or the environment.

2.4 Safety Instructions for Assembly/Disassembly

Only trained and qualified persons may perform installation/maintenance work.

Note: Ensure suitable transient protection devices are fitted to controlled electrical relays or valves. Ensure correct wiring of the crane's main contactor and the manual radio transfer switch.

- Isolate the system from the electrical power in accordance with the applicable regulations.
- Observe user-specific regulations.
- Only use suitable tools.
- Secure the installation area.

2.5 Operation of OCUs and MCUs with Identical System Address

To ensure safe operation, OCUs and MCUs are uniquely paired by way of a unique system address. This system address will only be assigned once by the manufacturer.

	CAUTION
	Conflict of Addresses: The user must ensure that the system address is used as designed and intended for a single system. The system address is marked on the master TransKey; the OCU and intended MCU address must match. In the event of a breach of this undertaking, the user is liable for any resulting damage/loss and shall indemnify the manufacturer against all third-party liability claims.



3. General

With an OCU and a matching MCU, a machine such as a crane or vehicle can be remotely radio controlled, avoiding the need for a wired connection between the human interface and the controlled device. A number of different control elements are integrated into the OCU housing so that commands to the device securely encode into a radio transmission. The MCU is then able to receive this transmission, securely decode these commands, and provide suitable interfaces to drive the machine.

3.1 Radio Transmission

The transmission between the OCU and MCU is performed by means of radio communication. With regard to the actual radio frequency that is used, there are several radio frequency bands available.

A specific RF frequency band and channel will often have been selected prior to delivery of the system. Depending on the frequency band, a certain number of RF channels are available.

The OCU and MCU must operate on the same RF channel in order to be able to communicate

3.1.1 Continuous Transmission

Typically, transmission is continuous and the MCU uses this as part of the information required to maintain the safety relays in an active state. If the MCU does not receive a valid telegram in this mode for a certain period of time, it automatically turns off; i.e., safety relays and command relays open. Depending on the application, the time varies from 0.5 s to 2.0 s.

In order to ensure optimum communication between the OCU and the MCU, ideally operate the OCU with line of sight to the MCU antenna at all times. Avoid total shielding of the signal path by metallic and other solid obstructions.

In some configurations, the MCU may be configured to operate safely in the absence of RF signal, much as a safety PLC will do. Such applications are strictly defined.

3.1.2 Radio Interference

Signals from other RF-emitting sources might interfere with the radio communication between the OCU and MCU. If the radio link is affected by these sources, changing the RF channel or even the RF band might be necessary.

3.2 Telegram Security

The transmitted telegram contains several security features.

3.2.1 Frame Type

Each message has an 8-bit message type identifier that is unique to the equipment in use.

3.2.2 System Address

This system uses a 24-bit addressing scheme, with each OCU/MCU pair sharing a common, unique system address. This system address is contained in every telegram sent by the OCU and is checked by the MCU every time a RF signal is received. The MCU processes a command only when the address in the telegram and the address stored in the MCU match. This is a safety measure to ensure that the MCU will act only upon its assigned OCU.

3.2.3 CRC

The telegram is checked for integrity using a 16-bit CRC; frames containing mismatched CRC will be rejected.



3.2.4 Frame Counter

Each message has an 8-bit embedded frame counter that changes on every data frame; this prevents frozen data and data frame hacking.

3.3 System Parameters

The system parameters, including the system address and the selected RF channel, are set by programming the TransKey. This is a removable radio frequency identification device (RFID) located inside the OCU and MCU. It is programmed by the manufacturer.

Note: Please refer to the separate 'Configuration Data' documents for the specific system parameter settings of your system.



4. MCU Overview

4.1 General

Portable Remote Control (PRC) systems offer the safety and dependability required for industrial control applications, including those with reversing motor control such as overhead cranes, conveyors, etc. The MCU described in this manual incorporates high-performance microprocessors and an advanced design that is compliant with all standard global requirements.

This MCU can be operated with one or more operator control units (OCUs). Basically, in its most simple form, the OCU is a radio transmitter and the MCU is a radio receiver. A radio frequency (RF) receiver, decoder and relay interface contained in the MCU is under the direct control of the operator with the OCU.

The CT24 MCU is supplied in three different size enclosures: the smaller CT24-9 and CT24-9-ASO, the medium CT24-17 and the larger CT24-32 (some variations exist for each with fewer relays).

The standard MCU operates from a 110–240 VAC input supply and is shown below:

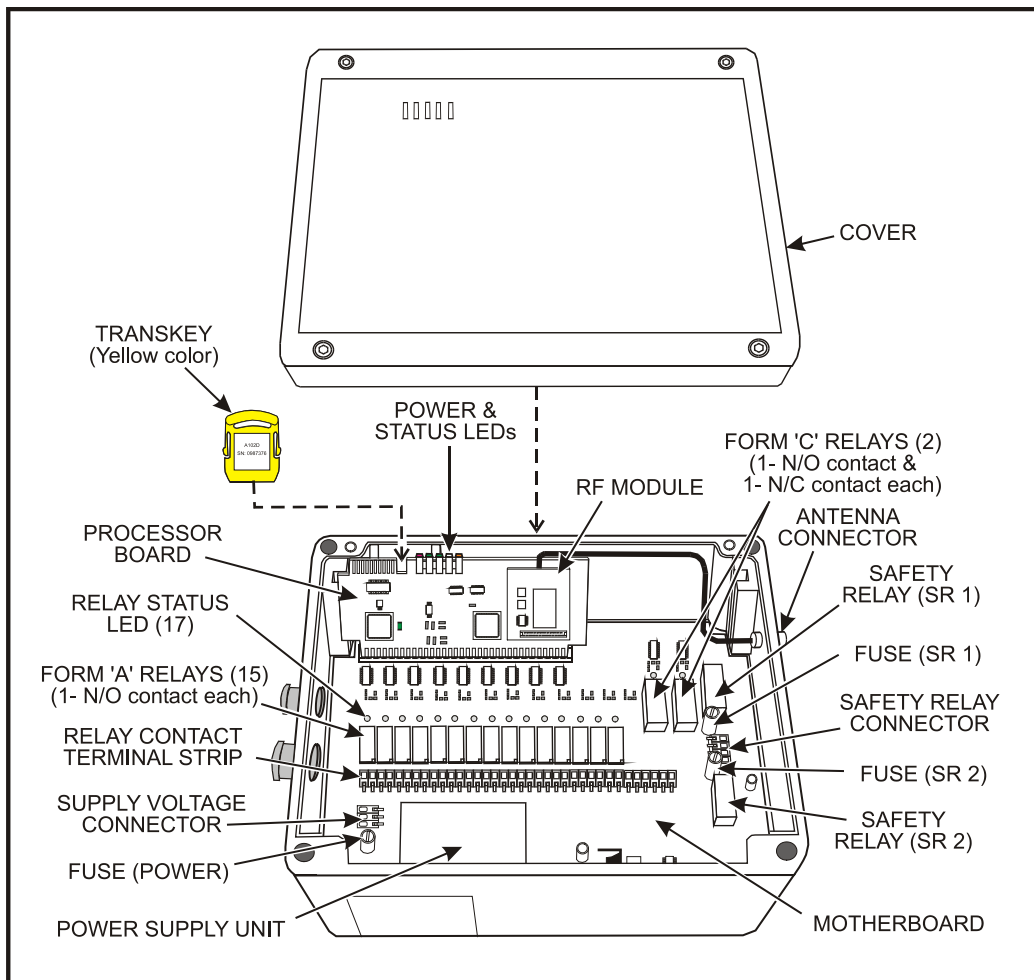

Figure 1: Typical CT24 MCU Component Layout (CT24-17 shown here)



The enclosure output interface to the controlled machine is handled by relays rated for typical machine interfaces. Each relay has an adjacent 'STATUS' LED that illuminates when the relay is energized.

Note: These relay 'STATUS' LEDs are only visible when the cover has been removed from the MCU.

Individual relay outputs are routed to the controlled equipment via a terminal strip.

When a fault condition is detected, the main contactor safety relays and all other outputs are disabled.

Note: The CT24-9-ASO, CT24-17 and CT24-32 main contactor safety relays KO-S and KO-M are each protected with a fuse. The CT24-9 has a single fuse. If the OCU is communicating with the MCU and the machine Mainline Contactor fails to energize, these fuses should be checked for continuity.

Just like the OCU, MCUs use a removable 'TransKey' to define and enable the appropriate operating parameters.

Note: OCU and MCU TransKeys must not be swapped. The OCU (transmitter) TransKey is black. The MCU (receiver) TransKey is yellow. Swapping TransKeys will result in OCU/MCU fault indications and the system will not operate.

4.2 Antenna

The receiver may be supplied with either an internal or external antenna. To ensure optimum communication, the transmitter and the receiver should be installed with line of sight between the antennas of both units. Any shielding by metallic constructions should be avoided.

If the receiver is installed inside a metallic enclosure, a detached antenna is required.



4.3 CT24-9

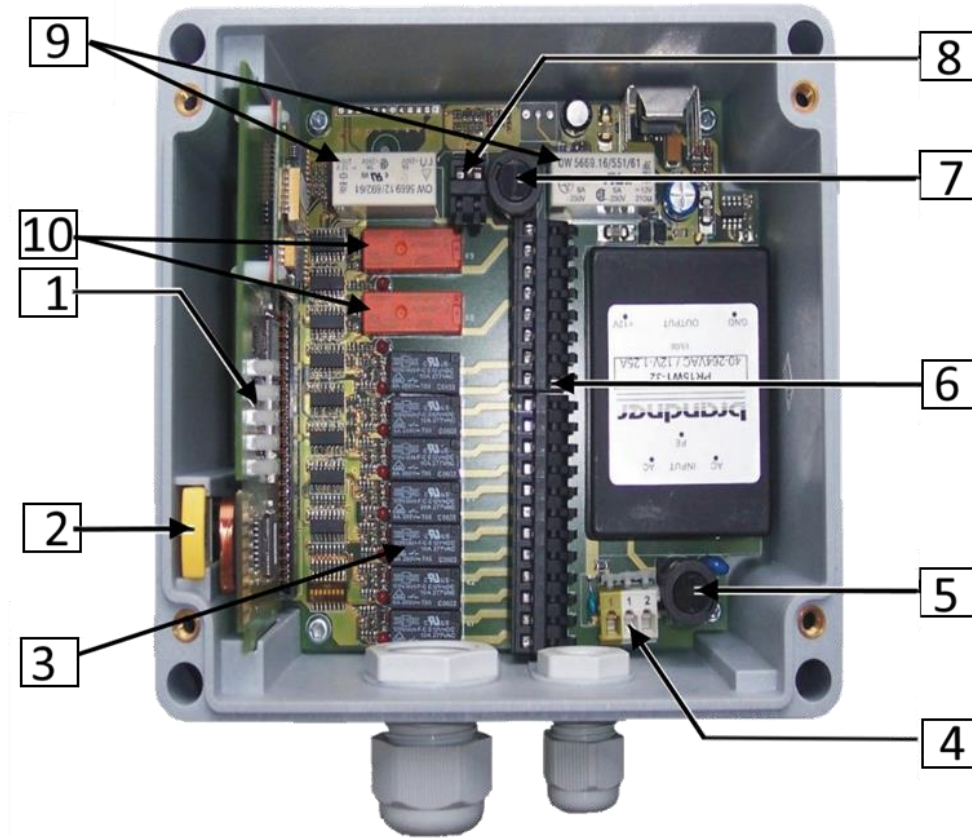

Figure 2: CT24-9 MCU

This MCU has two main contactor safety relays with one fuse and one pair of terminals, seven N/O relays and two C/O relays. The following items are identified in Figure 2:

1. Status LEDs on micro board
2. TransKey inserted in slot inside enclosure
3. Seven N/O function relays
4. Terminal main input voltage
5. Fuse main input
6. Removable terminal strip for function relays
7. Fuse for main contactor safety relays
8. Terminal strip for main contactor safety relays
9. Two main contactor safety relays
10. Two C/O function relays



4.4 CT24-9-ASO

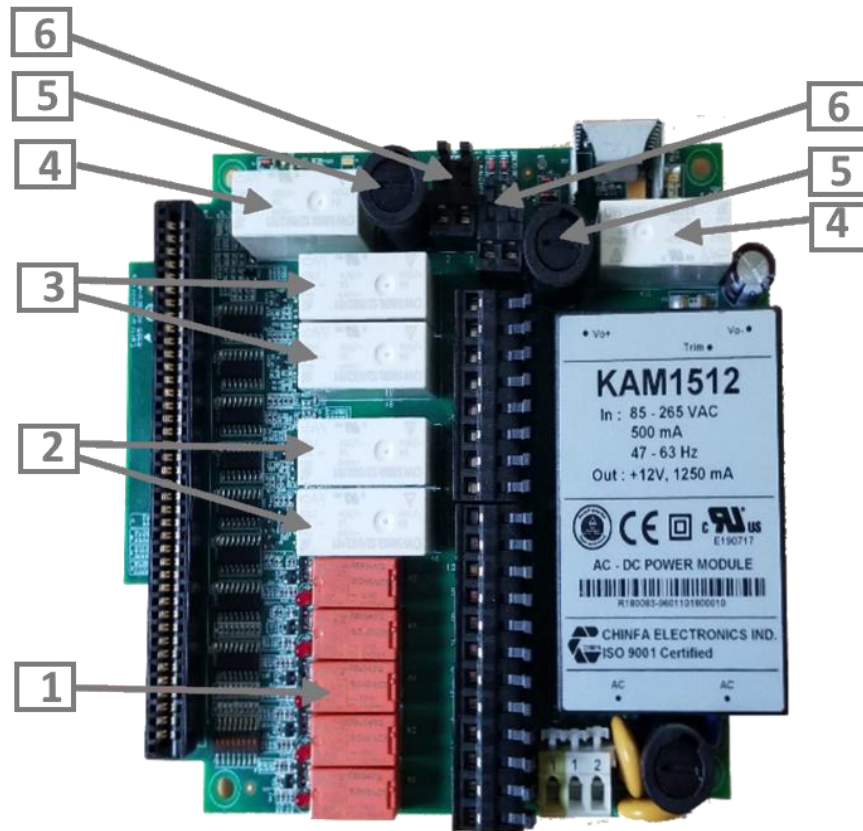

Figure 3: CT24-9-ASO MCU

This MCU has an enhanced safety design that is enabled by the additional provision of safety relays on four of the motion control outputs.

This MCU has two separated main contactor control safety relays each with a fuse and terminals block, and five standard motion control relays, organized as below and identified in the figure above:

1. Five N/O function relays
2. Two N/O function safety relays
3. Two C/O function safety relays
4. Main contactor safety relays
5. Fuses for main contactor safety relays
6. Terminals for main contactor safety relays

NB: If you are replacing a CT24-9 relay board with a CT24-9-ASO relay board, it will be necessary to link the two safety main contactor relays in series with an additional link wire between the two terminal blocks 6.



4.5 CT24-17

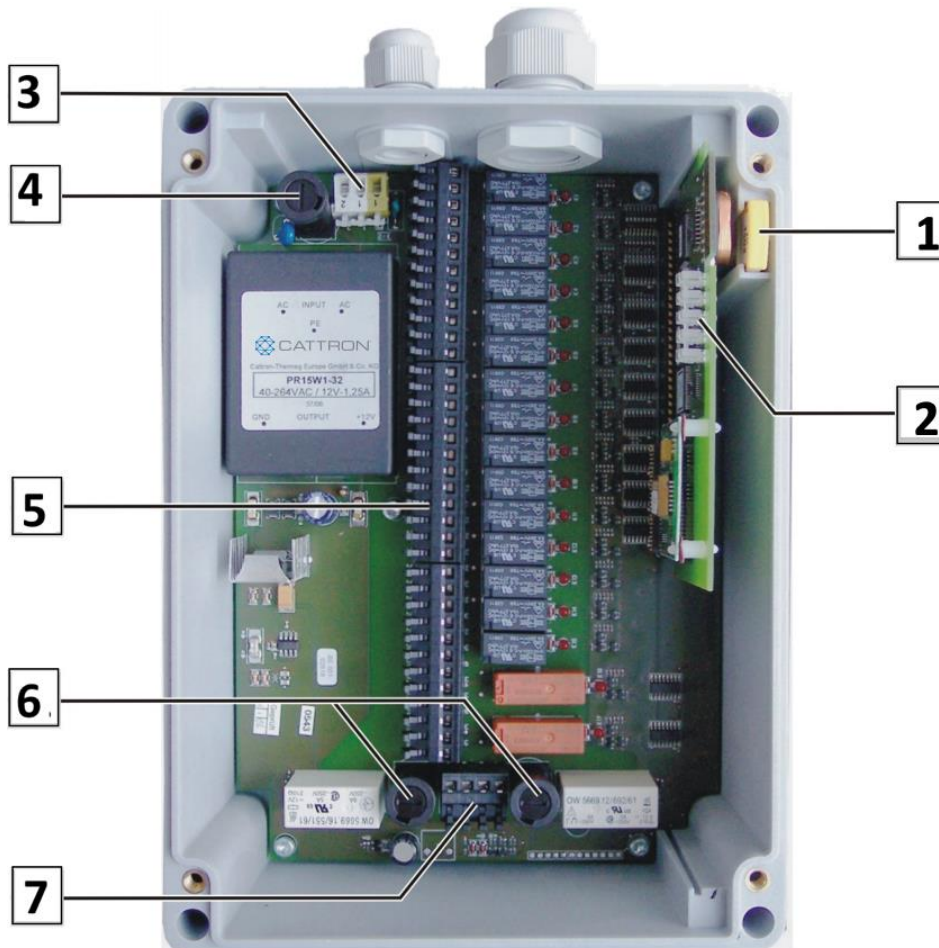

Figure 4: CT24-17 MCU

The following items are identified in Figure 4:

1. Transkey
2. Status LEDs
3. Terminal main input voltage
4. Fuse main input
5. Function relay plug in terminal strips
6. Fuses for main contactor safety relays
7. Terminal strip for main contactor safety relays



4.6 CT24-32

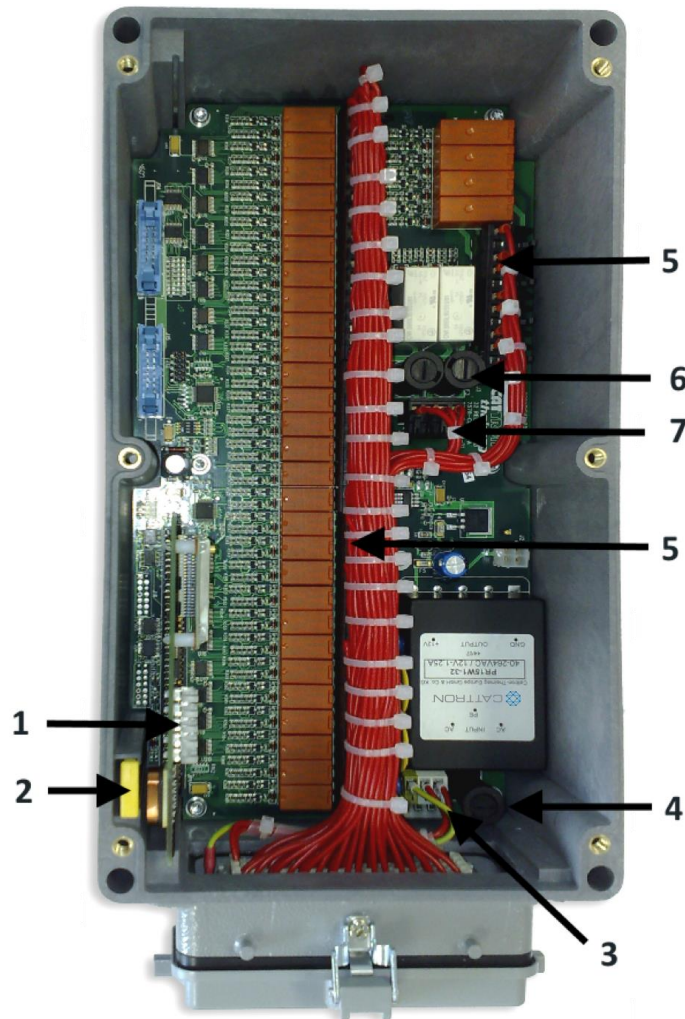

Figure 5: CT24-32 MCU

NB: Optional HAN style connector shown fitted

The following items are identified in Figure 5:

1. Status-LEDs
2. TransKey
3. Terminal main voltage
4. Fuse mains
5. Removable terminal strips for function relays
6. Fuses for main contactor safety relays
7. Terminal strip for main contactor safety relays



4.7 Status LEDs

As illustrated in the following figure, all CT24 MCUs have five externally visible LED indicators on the front cover that display the current system status to the operator. The status/fault messages associated with each LED are described in Table 1.

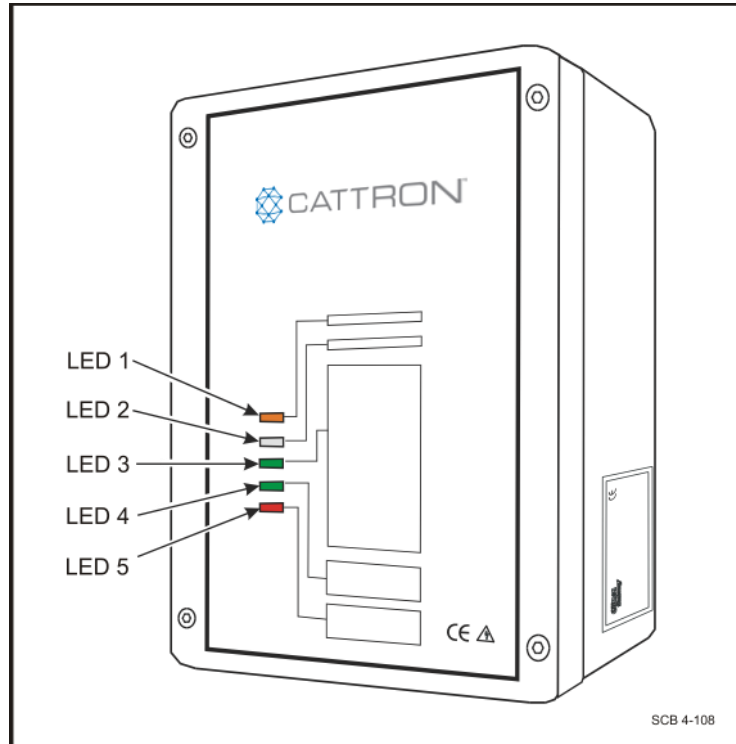

Figure 6: MCU System Status LEDs (all CT24 versions)

Table 1: MCU External Status/Fault LED Messages

MCU EXTERNAL LED INDICATORS	DESCRIPTION
1. Power On	Illuminates orange when the MCU receiver has voltage
2. Scan Mode	Flashes red/orange in Scan Mode Not used when system is configured for fixed frequency
3. RF Reception	Illuminates green when valid data from the OCU is received and both safety relays are energized Illuminates orange if valid data from the OCU is received and the safety relays are de-energized Illuminates red if data from another OCU (with invalid address) is received
4. Command	Illuminates green when commands are received from the OCU (normal condition)
5. Fault indication	Blinks red when the MCU detects a fault (refer to the Appendix on Error Codes for the blink sequence and the corresponding fault messages)



Referring to [Figure 7](#), an additional processor status LED indicator is mounted on the MCU processor board and may be viewed by removing the MCU front cover. This LED blinks orange if the receiver does not detect a transmitter and green if valid messages are received. In addition, if the second processor detects a fault, this LED blinks red.

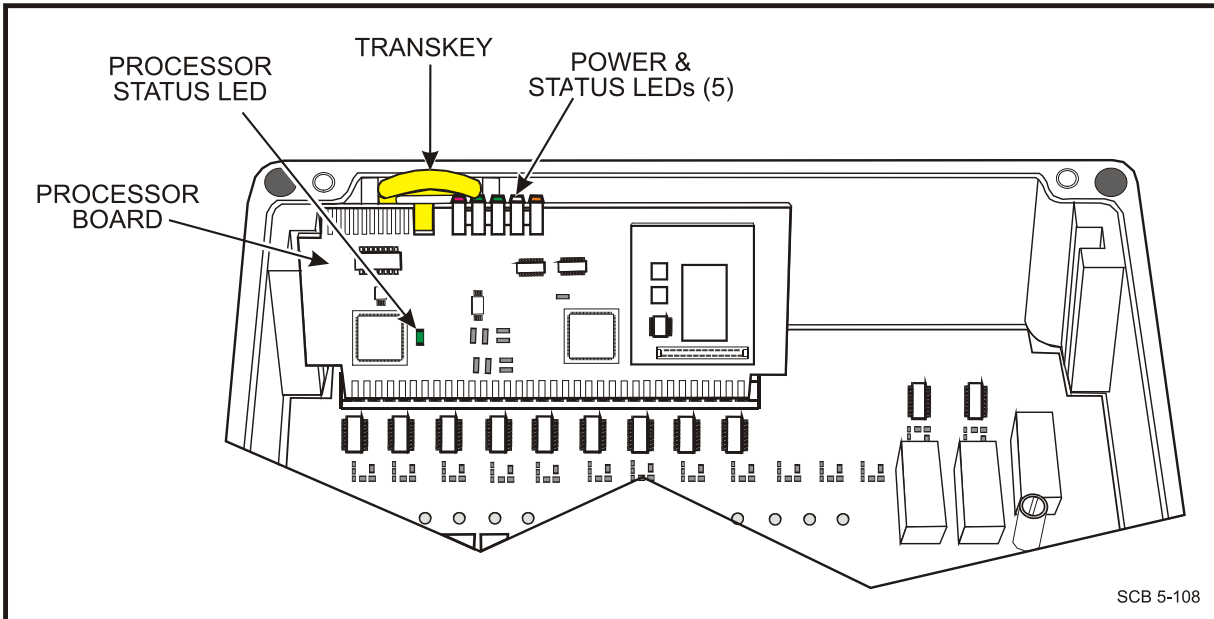

Figure 7: MCU Status and Fault LEDs

4.8 Optional 9-36 VDC Input MCUs

Optional 9-36 VDC input MCUs, Part Number 1MCU-7608-Annn, are available. This MCU is identical to the standard MCU except that the power supply on the relay board is changed.



5. Installation

5.1 General

Only a specialized electrician should install the system. It is essential to observe and meet the various local and national regulations that are applicable, such as VDE, BDE, UL, CSA, etc.

Important: Install suitable interference and transient protection devices on loads.

5.2 Mounting

5.2.1 Choosing a Mounting Location

The MCU enclosure must be installed in a location that allows easy access for maintenance and service, together with a clear line of sight to the transmitter. Adequate clearance must be allowed to remove the cover for access. If the external antenna is to be mounted on the enclosure, its location must also provide adequate RF reception range and clear line of sight to the transmitter.

Note: The MCU is not rated for outdoor use unless it is installed within a secondary enclosure.

Select a location to minimize any possible interference from RF sources such as motors. Ideally, the MCU enclosure should be installed as close as practical to the controlled machine's electrical cabinet. All wiring entering the enclosure must be terminated inside the enclosure.

Note: Do not install any pass-through wiring.

To prevent interference on signal lines, do not install high and low voltage cables in the same conduit. The standard MCU is shipped with an external antenna. When installing the external antenna, keep the antenna wire separate from all other wiring, both inside and outside the MCU enclosure.

Note that optional Shock Mounting Bracket Assemblies are available. These items include Wall Holder Part Number MT 009-00572 (quantity two), Rubber Insert Part Number MT 009-00592 (quantity four), and Ball Bearing Cage Part Number MT 009-00593 (quantity four). Contact Cattron at www.cattron.com for this option.

The following three figures show the mounting dimensions and drilling locations for the MCU enclosure.



Mounting Dimensions

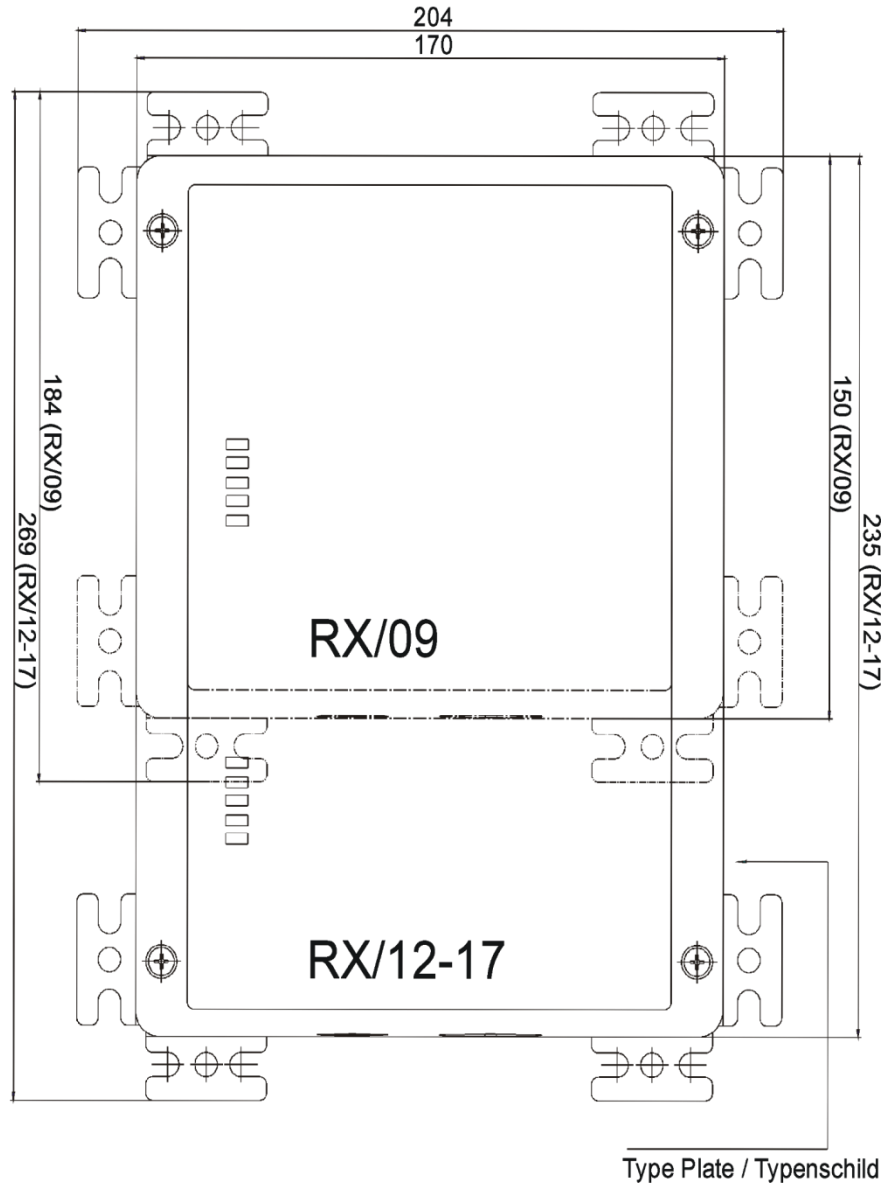

Mounting drill holes for RX/12-17:

Affix installation bracket with self-shaping plastic screws.

- 155mm x 219mm M4/M5 Without mounting bracket, fastened through the case
- or 129mm x 250mm M6 Mounting bracket top and bottom of case
- or 185mm x 194mm M6 Mounting bracket left and right of case

Figure 8: CT24-9 and CT24-17 MCU Enclosure Mounting Dimensions Drawings



Mounting Drill Holes

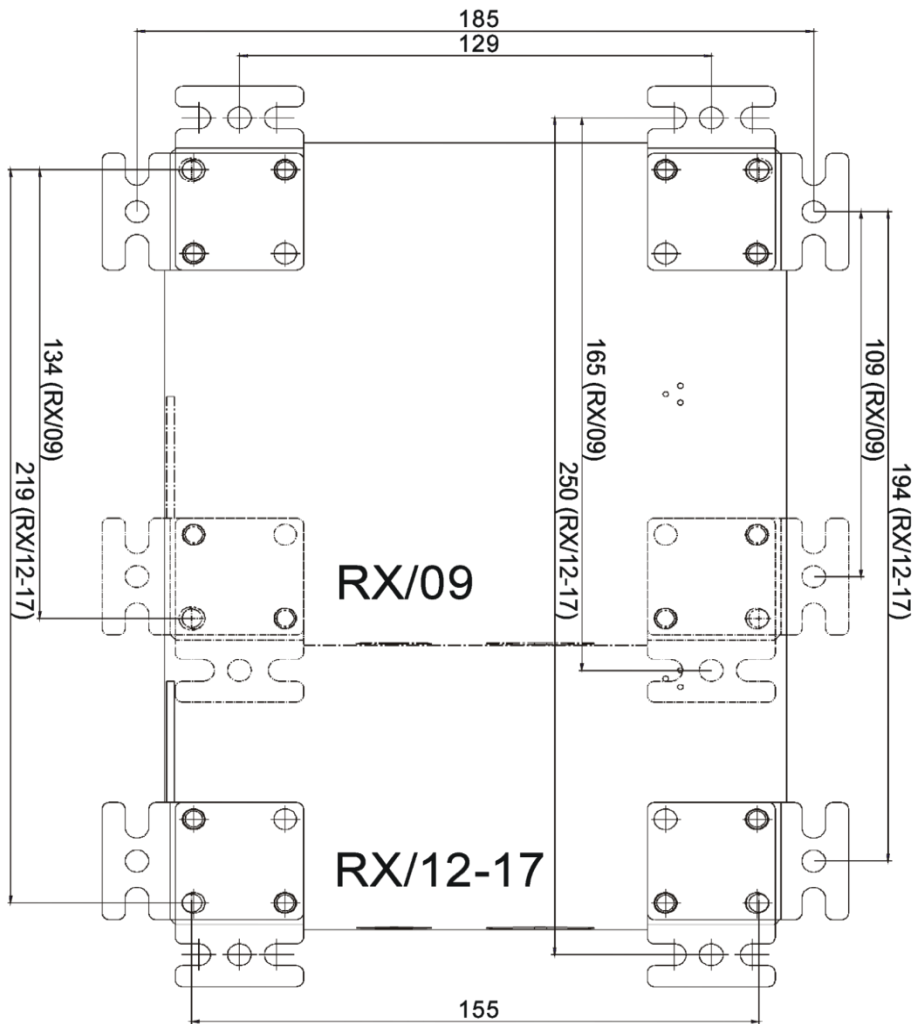

Mounting drill holes for RX/09:

Affix installation bracket with self-shaping plastic screws.

- 155mm x 134mm M4/M5 Without mounting bracket, fastened through the case
- or 129mm x 109mm M6 Mounting bracket top and bottom of case
- or 185mm x 165mm M6 Mounting bracket left and right of case

Figure 9: CT24-9 and CT24-17 MCU Enclosure Mounting Drilling Drawings



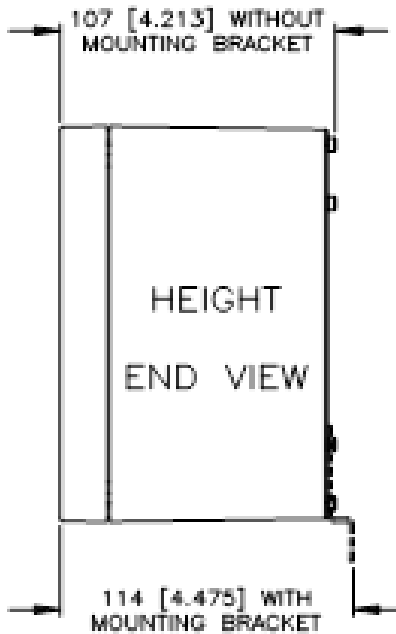
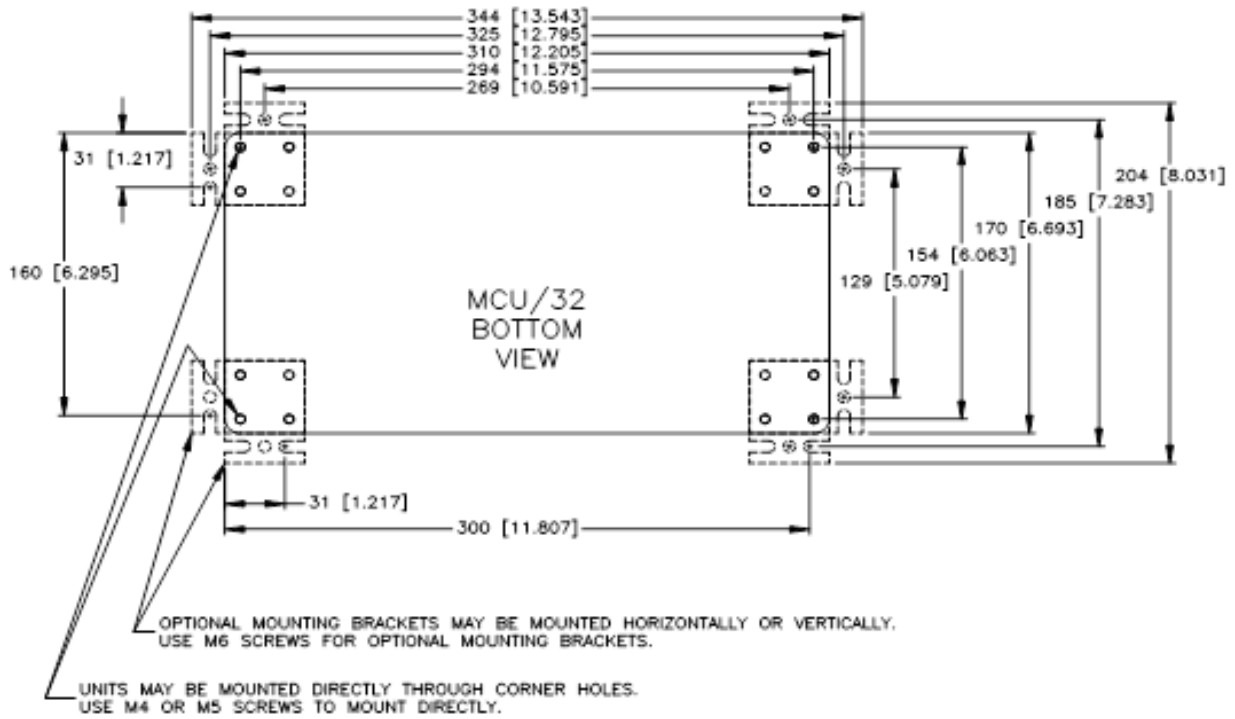

Figure 10: CT24-32 MCU Enclosure Mounting Drilling Drawings



5.3 Interface

The actual wiring configuration depends on the work/configuration sheet supplied with your system. This section provides general guidance of the selection of wire types for your application.

5.4 Relay Rating

Relay switching current are rated at 5A 250Vac and 5A 24Vdc.

5.5 Interface Wiring

Before installing the system, you are advised to prepare an electrical wiring diagram that defines all electrical interface connections between the system and the equipment being controlled. We also advise you to first read the following topics of discussion. Additionally, you should locate and refer to the example mainline drawing provided.

5.6 Safety Critical Interfaces

	WARNING
	<p>UNLESS SPECIFIED, REMOTE CONTROL SYSTEMS ARE NOT DESIGNED TO INTERFACE DIRECTLY TO SAFETY CRITICAL BISTABLE MAINTAINED FUNCTIONS (i.e., magnetic circuits, vacuum circuits, grab, pump motors, fire suppression, etc.).</p> <p>A PROPER INTERFACE TO SAFETY CRITICAL BISTABLE MAINTAINED FUNCTIONS SHALL BE INSTALLED, IDEALLY USING A RELAY INTERFACE UNIT.</p> <p>SHOULD CATTRON SYSTEMS BE INADVERTENTLY CONFIGURED TO INTERFACE DIRECTLY WITH SAFETY CRITICAL BISTABLE MAINTAINED FUNCTIONS AT YOUR OPERATING FACILITY, DAMAGE TO EQUIPMENT, SERIOUS INJURY OR DEATH TO PERSONNEL MAY RESULT.</p> <p>IT MUST BE FULLY UNDERSTOOD THAT CATTRON WILL NOT BE HELD LIABLE FOR PERSONAL INJURY, DEATH, EQUIPMENT OR PROPERTY DAMAGE WHICH MAY ARISE FROM IMPROPER CONFIGURATION OF YOUR REMOTE CONTROL SYSTEM.</p>

When safety critical bistable maintained functions (i.e., electro-magnetic circuits, vacuum circuits, grab, pump motors, fire suppression, etc.) are part of your controlled equipment, a proper interface must be installed between the system and all such functions before operational use. We strongly recommend you use a relay interface unit.

5.7 Power and Control Cables Interface

The three possible options for installation of the power and control cabling are as follows:

1. Use the supplied Cable Gland (I/D 0.6875 inch) and install a high-performance multi-core cable
2. Protective conduit with individual wires
3. HAN style multi pole connector

It is important to note that the maximum current carrying capacity of the relay contacts is 5 A at 240 VAC resistive load. When connected to contactors, the MCU relay contacts should be protected with suitably rated transient suppression devices to maximize contact life expectancy; if these are not supplied as part of the MCU, they will need to be fitted to the contactors being switched.



5.8 Determination of Correct Control Circuit Wire Gauge

International Standards define the limiting factors that must be applied to wiring connections in this type of equipment. In general, any wiring that has voltage on it which is greater than 30 VAC or 42.2 VDC is required to comply with the recommendations below.

The cabling used must be suitable for the rated load imposed by the device being controlled. Where the voltage exceeds that mentioned above of 30 VAC or 42.2 VDC, the wire should not be less than 24 AWG or 0.2 mm² in order to comply with International Electrical Safety Standards.

Rules defining wire gauge are many and depend on factors such as temperature, wire bundling, number of loaded wire pairs, duty cycle of output function, etc.

In order to simplify the process, the following sections provide a guide to the wire size that should be used to ensure compliance with the necessary regulatory standards in the EU and NA.

Note: Use the wire size or larger for the required current load; note that the values shown in



Table 2 are based on cable with insulation rated at 105°C.



Table 2: Wire Selection Table

1	2	3	4		5	6	7	8
STANDARD	TABLE	ITEM	DETAIL		WIRE CAPACITY AMPS	BUNDLING FACTOR APPLIED FOR 10 PAIRS	DUTY CYCLE MACHINE OR MAINTAINED OUTPUT @	DUTY CYCLE STD CRANE @
IEC60204-32			<i>Using the worse bundling factor from IEC60204-32 and duty cycle correction factor from IEC60204-32, and applying to wire capacity from CSA 22.2#14 NB: Wire sizes less than 0.459 mm² (24 AWG) are not recommended.</i> Table 3				100%	25%
					multiplier	0.55	1	1.265
	C3	Bundled Cables	0.55 for 10 pairs, worse than CSA 22.2#14 at 0.7					
	D1	Duty Cycle Correction	1.265 @ 25% for a standard Crane					
			AWG	mm ²				
CSA 22.2#14	3 col 5	Wire Capacity	14 AWG	2.08	15.00	8.25	8.25	10.44
			16 AWG	1.31	9.00	4.95	4.95	6.26
			18 AWG	0.823	6.00	3.30	3.30	4.17
			20 AWG	0.518	4.00	2.20	2.20	2.78
			22 AWG	0.326	3.00	1.65	1.65	2.09
			24 AWG	0.205	2.00	1.10	1.10	1.39
	4	Bundled Cables 7-24	0.7					

5.8.1 For High Duty Cycle Applications

For example, for multiple constant output functions such as function select (magnet/hoist/maintained functions), use values from Column 7.

5.8.2 For Low Duty Cycle Applications

For example, for motion functions such as hoist, travel, rotate, etc., use values from Column 8.



NOTES:

- Wires must be bundled to keep mechanical rigidity and maintain good wiring practice.
- 16 AWG (1.5 mm) is the minimum gauge that can be used if the load is unknown, up to the relay rating of 5A, and in a normal industrial environment of 40°C.
- Lower gauges may be used for known low current loads.
- Care must be taken with any common supply wires as these will be carrying the load of many outputs.

5.9 Examples of Wire Sizing

5.9.1 Low Duty Application (Typical Crane)

A typical crane contactor (sealed) would have a rating less than 40W; however, contactors vary widely and the rating should be checked.

For a five speed function (intermittent use):

- The common wire may be carrying 200 W (=5X40) at 48 VAC, for a current of 4 A (=200/48). Therefore, 18 AWG might be used.
- The actual drive out to a single hoist contactor could be 0.83 A (=40/48), so 24 AWG would be adequate.
- If the voltage were 110 VAC, the current would be 1.8 A, so 22 AWG might be used.
- The actual drive out to a single hoist contactor could be 0.36 A, so 24AWG would be adequate.

5.9.2 High Duty Application (Crane with Multi Select or Machine)

For a multi select set of five outputs (continuous):

- The common wire may be carrying 200 W (=5X40) at 48 VAC, for a current of 4 A. Therefore, 16 AWG might be used.
- Each select output might be 0.83 A (=40/48), so 24 AWG would be fine.

5.9.3 High Duty Maximum Current Application

For multiple outputs running 5 A loads (continuous):

- Common carrying up to two relay loads is possible using 14 AWG; otherwise, use 16 AWG.
- Each relay output conductor requires 16 AWG.

5.10 Connection of Wires to Interface Connectors

While it is possible in some cases to use wires without ferrules, sometimes the use of ferrules will inevitably make the connection to the RIA and Phoenix interface connectors easier and neater. The use of ferrules may also be required when looping a common feed to multiple relays, particularly if it is determined that larger wire gauges are necessary. The following section will simplify the selection of ferrules according to the pre-determined wire gauges.

5.10.1 Interface Connectors

These may have either a spring clamp or a screw connector.

5.10.2 Overview

All of the machine interface connections used on the MCU have pluggable terminal blocks for easy maintenance and board replacement.



Both spring clamps and screw terminals are available.

5.10.3 Spring Clamp Type Inserting a Wire

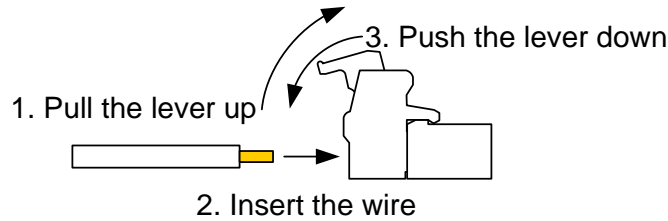

Figure 11: Inserting a Wire

5.10.4 Spring Clamp Type Removing a Wire

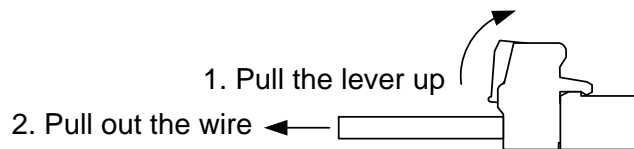

Figure 12: Removing a Wire

5.10.5 Terminal Specifications

NB: Wire sizes less than 0.459 mm² (24 AWG) are not recommended.

Table 3: Terminal blocks

TYPE	ALL EXCEPT ANALOG	ANALOG	WIRE RANGE	AWG
Spring clamp	ASP046 series	ASP044 series	0.459 mm ² to 1.5 mm ²	24 to 16
Screw	249 series	n/a	0.459 mm ² to 2.5 mm ²	24 to 13

5.10.6 Ferrule Types

Ferrules can support wires sizes from 12 to 24 AWG. Both single wire and dual (double) wire ferrules are available, as shown in the following figures.



Figure 13: Single Wire Ferrules



Figure 14: Dual Wire Ferrules



Table 4: Ferrule Selection

WIRE GAUGE (AWG)	RIA CONNECTOR WITH SPRING CLAMP		RIA CONNECTOR WITH SCREW	
	SINGLE FERRULE	DOUBLE FERRULE	SINGLE FERRULE	DOUBLE FERRULE
12	X	X	X	X
14	X	X	☑	X
16	☑	☑	☑	☑
18	☑	☑	☑	☑
20	☑	☑	☑	☑
22	☑	☑	☑	☑

☑: valid X: not valid

Table 5: Terminal Capacity for Wires Without Ferrules

WIRE GAUGE (AWG)	CONNECTOR WITH SPRING CLAMP	CONNECTOR WITH SCREW
10	X	X
12	X	X
14	X	1
16	1	1
18	1	1
20	2	2
22	2	2
24	2	2

Note: The use of ferrules is recommended with spring clamp terminals.

The spring block terminals are suitable for a wire range of 24 AWG (0.2 mm²) to 16 AWG (1.31 mm²).

If you are using two wires in the same terminal, then the limit is 20 AWG (0.518 mm² per wire).

If larger wires (up to 14 AWG or 2.5 mm) are required, then screw terminals can be substituted or ferrules can be employed.

Note: Where the voltage exceeds 30 VAC or 42.2 VDC, the wire used should not be less than 24 AWG (0.2 mm²) in order to comply with International Electrical Safety Standards.



Table 6: Terminal Blocks – Spring Clamp

TYPE	ALL EXCEPT ANALOG	ANALOG	WIRE RANGE	AWG
Spring clamp	ASP046 series	ASP044 series	0.08 mm ² to 1.5 mm ²	28 to 16

Table 7: Terminal Blocks – Screw Type

TYPE	ALL EXCEPT ANALOG	ANALOG	WIRE RANGE	AWG
Screw	249 series	n/a	0.08 mm ² to 2.5 mm ²	28 to 12
Screw	n/a	369 series	0.08 mm ² to 1.5 mm ²	28 to 16



6. MCU Connections

The following pages show the respective terminal strip connections within the MCU enclosure.

The actual wiring to the machine depends on the specific configuration sheet supplied with your system.

6.1 CT24-9

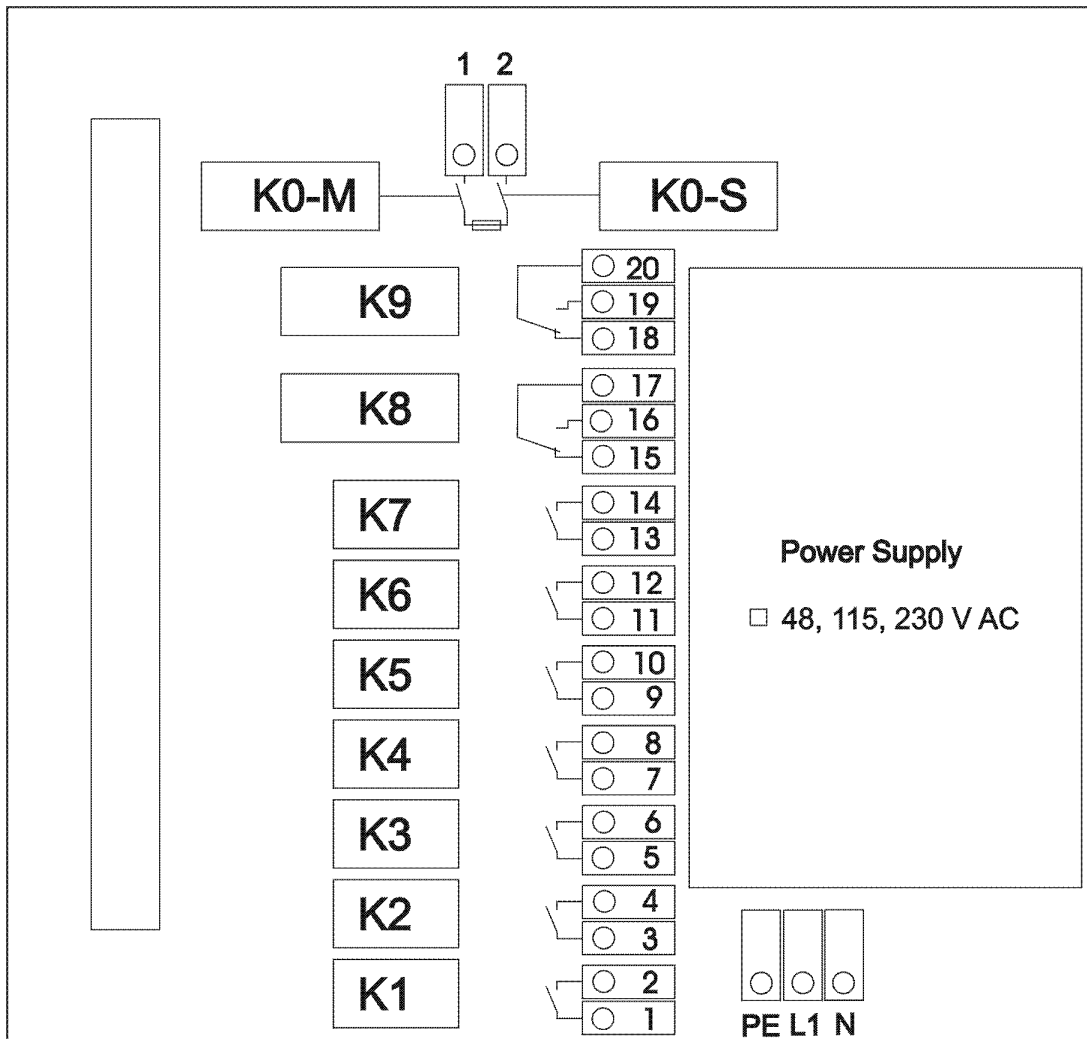

Figure 15: CT24-9 Relays and Terminals



6.2 CT24-9-ASO (AC version)

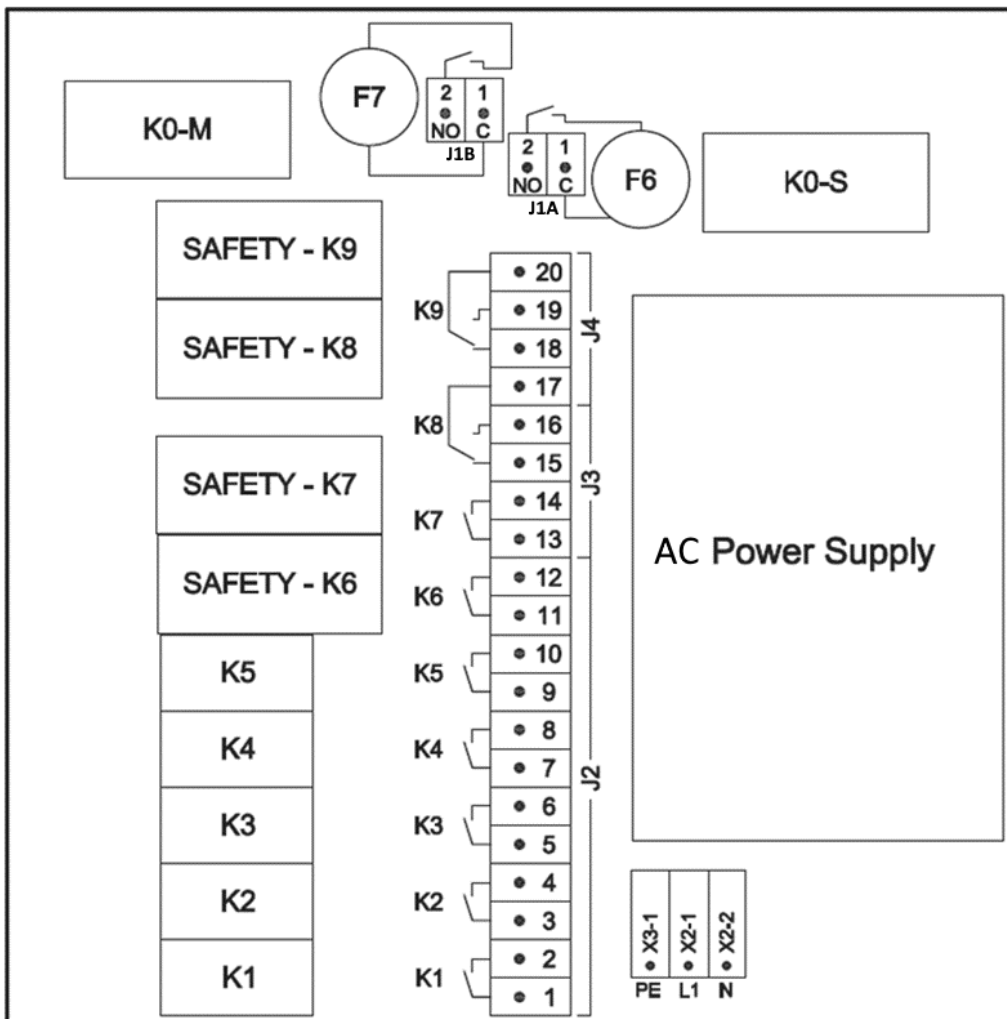

Figure 16: CT24-9-ASO AC Version Relays and Terminals

6.2.1 Replacing a CT24-9 with a CT24-9-ASO

It should be noted that the CT24-9-ASO has enhanced safety using safety relays on K6 through K9 and that the Main Contactor relays K0-M and K0-S have separate fuses and terminal strips.

When replacing a CT24-9 board with a CT24-9-ASO board, it will be necessary to link J1A N/O terminal to J1B C terminal and to take the J1 C terminal and J2 NC terminal to the machine main contactor control circuit, as the CT24-9 only has one terminal pair.



6.3 CT24-9-ASO (DC Version)

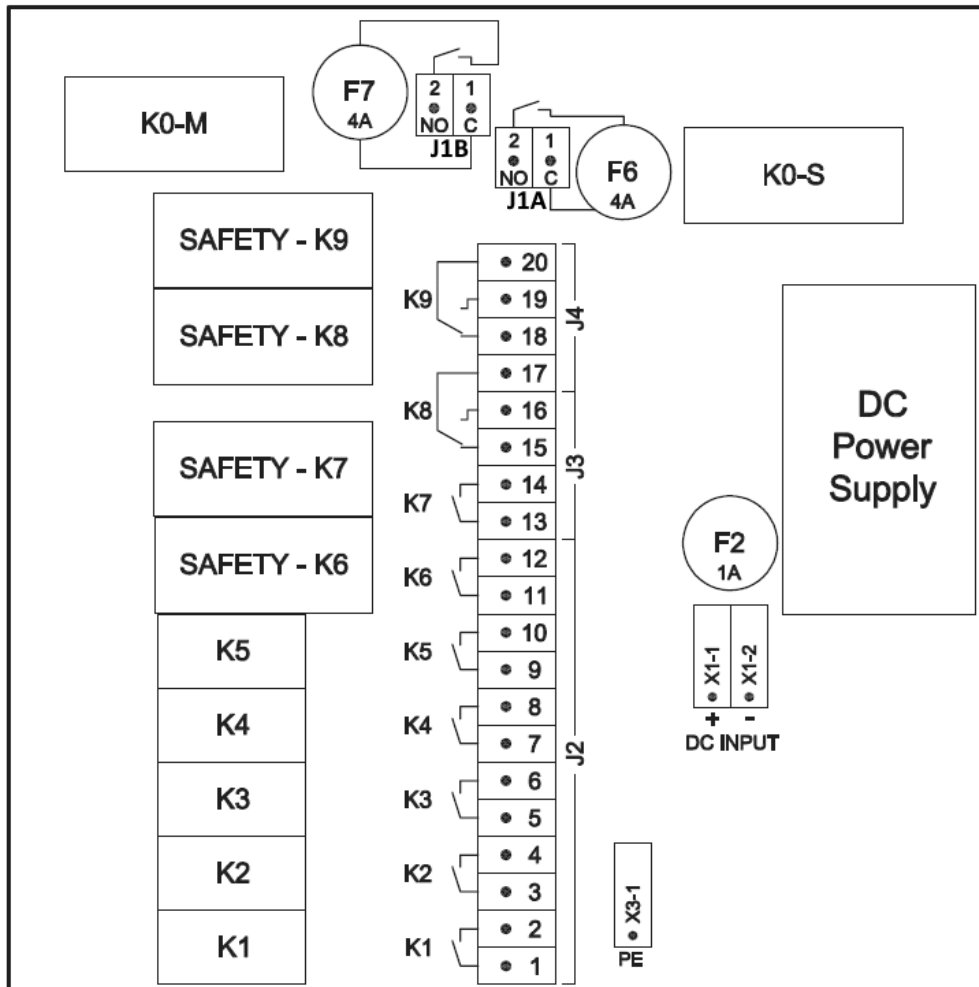

Figure 17: CT24-9-ASO DC Version Relays and Terminals

6.3.1 Replacing a CT24-9 with a CT24-9-ASO

It should be noted that the CT24-9-ASO has enhanced safety using safety relays on K6 through K9 and that the Main Contactor relays K0-M and K0-S have separate fuses and terminal strips.

When replacing a CT24-9 board with a CT24-9-ASO board, it will be necessary to link J1A N/O terminal to J1B C terminal and to take the J1 C terminal and J2 NC terminal to the machine main contactor control circuit, as the CT24-9 only has one terminal pair.



6.4 CT24-17

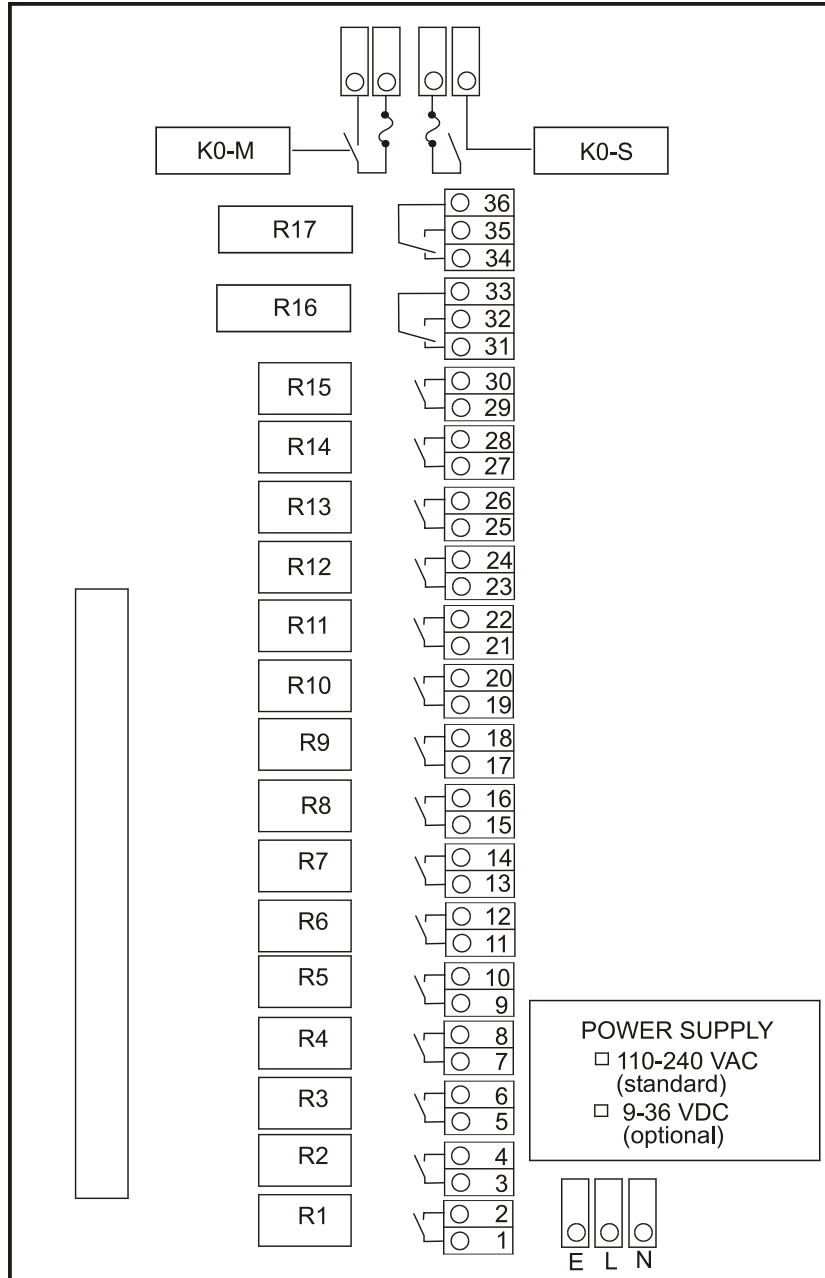

Figure 18: CT24-17 Relays and Terminals



6.5 CT24-32

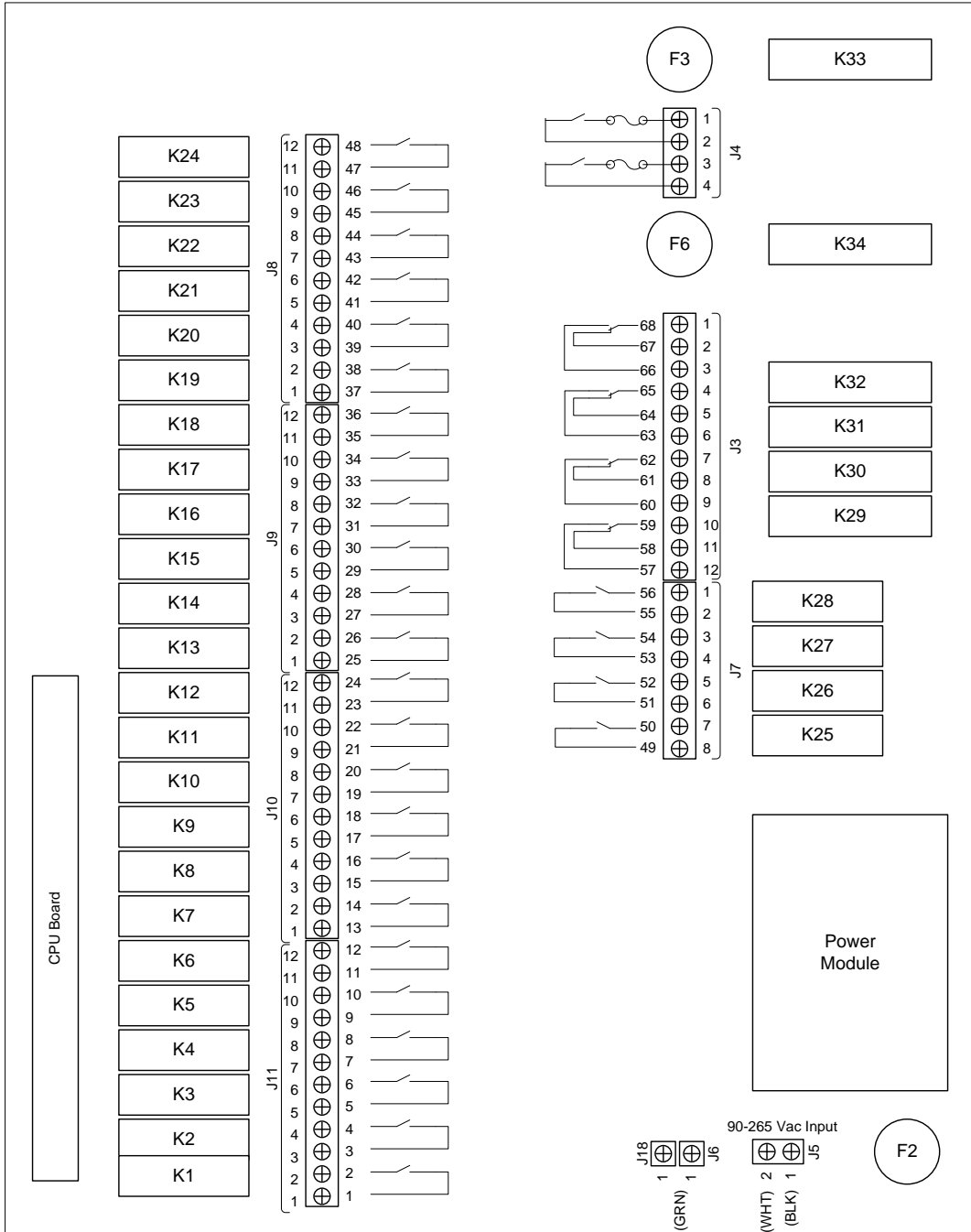

Figure 19: CT24-32 Relays and Terminals



6.6 Conduit

The fitted Cable Gland can be removed and a larger 1 inch diameter conduit fitted after boring out the fixing hole. When using non-metallic conduit, the additional Conduit Grounding Kit will not be required.

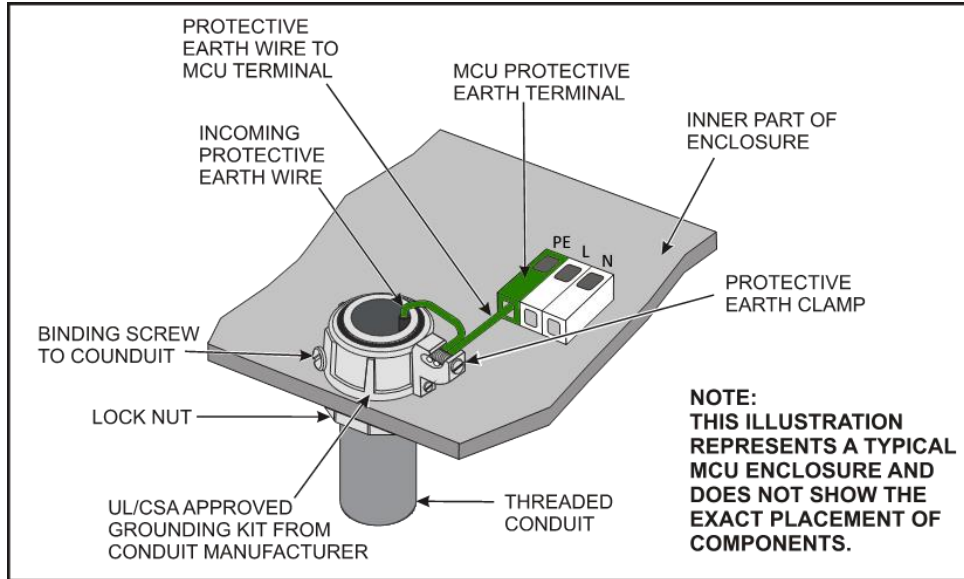

Figure 20: Metallic Conduit Installation

Metallic conduit must be grounded to an incoming earth wire of a gauge at least as large as the maximum supply gauge entering the enclosure. Referring to the figure above, metallic conduit is installed to the Conduit Grounding Kit and secured using the Lock Nut and the Binding Screw. Both the incoming Protective Earth (PE) wire and a wire from the MCU PE terminal must be connected and securely fastened to the Protective Earth Clamp.

Use a Conduit Grounding Kit as recommended by the conduit manufacturer that has an appropriate National Approval. A typical example would be an RACO type 1264 that carries UL/CSA approval.

	WARNING
	The CT24 MCU Housing is not suitable for connection of more than a single metal conduit.

Note: Wiring within the MCU housing must be neatly routed and secured, keeping the wires central in the enclosure and above the relays/connectors. Use cable ties or similar to prevent unwanted movement.



6.7 The Controlled Machine

The machine you are interfacing to may consist of single or multiple contactor panels, single or multiple manual controls, and single or multiple control transformers etc. Notice that there is no common connection between relay output contacts, allowing control of different power sources and combinations of AC and DC power.

Application of the normally open relay contacts is similar to wiring that is required for any control switch, such as a pendant. Standard wiring practices should be observed. These can be found in the National Electrical Code and in local codes that may apply for your area.

6.8 Control Power

Your MCU may have either an AC or DC power supply and the interface relays may be connected to either AC, DC or both.

The standard remote control system is 110-240 VAC, 50/60 Hertz, at less than 1 A. The system can be connected to an existing control transformer if the transformer's rating permits; otherwise, a separate control transformer must be supplied to provide the appropriate power for the remote control system.

Note: The MCU motherboard is protected by a 1 A/240 VAC fuse.

Using a separate control transformer helps by reducing chances of a power slump if other electrical components connected to it fail. It can also be sized to allow installation of a utility outlet near the MCU for connection of a light or test equipment.

6.9 Fuses

Fuses must be replaced with the correct type and rating, fuses are available from Cattron or may be obtained from an electrical distributor.

The fuse rating are;

AC Supply	1A 240VAC Cooper Bussmann, GMC series, Cattron part # PRT-0000392
DC Supply	1A 240VAC Cooper Bussmann, GMC series, Cattron part # PRT-0000392
MLC Relays	4A 240VAC Cooper Bussmann S500 series, Cattron part # PRT-0000393

6.10 Relay Outputs

Each output relay has at least one normally open (NO) contact which is available for wiring at the relay board terminal block (TB). These contacts are rated for up to 5.0 A at 110–240 VAC or 30 VDC.

Each output relay is completely independent of all other relays. There are no common connections between any output contacts. This allows the connection of different power sources, AC and DC, to each of the separate relays.



	<p>WARNING</p> <p>WITH THE EXCEPTION OF THE TWO SAFETY RELAYS, THE FUNCTION RELAYS IN THE MACHINE CONTROL UNIT (MCU) DO NOT HAVE INTEGRAL FUSING; IT IS THEREFORE IMPERATIVE THAT THE INTERFACE CIRCUITRY INCORPORATE THE REQUIRED OVERCURRENT PROTECTIVE DEVICES. THE PROTECTIVE DEVICES MAY BE INSTALLED IN INDIVIDUAL RELAYS OR IN RELAY GROUPS, BUT IN NO CIRCUMSTANCES SHOULD THE OVERCURRENT DEVICE RATING EXCEED THE MAXIMUM RELAY CURRENT RATING OF 5 A.</p> <p>REFER TO THE INSTALLATION DRAWINGS PROVIDED FOR GUIDANCE. DAMAGE TO EQUIPMENT OR SERIOUS INJURY OR DEATH TO PERSONNEL MAY RESULT. IT MUST BE FULLY UNDERSTOOD THAT CATTRON WILL NOT BE HELD LIABLE FOR PERSONAL INJURY, DEATH, EQUIPMENT OR PROPERTY DAMAGE WHICH MAY ARISE FROM IMPROPER INSTALLATION OF YOUR REMOTE CONTROL SYSTEM.</p>
---	--

6.11 Mainline Circuit

The safety relay K0-M and K0-S outputs are special. They MUST always be wired in series with the Function relays to ensure that safety is maintained.

The connection may be direct so that K0-M and K0-S provide power to the Function relays that then in turn power the device being controlled, or more likely K0-M and K0-S control a mainline (ML) contactor or similar device that is controlling the power to the machines functions.

When K0-M and K0-S are installed correctly, if a system fault were to occur, the machine will safely be brought to a safe state.

The use of K0-M and K0-S is mandatory for the safe operation of the machine.



ALL INSTALLATIONS MUST BE IN ACCORDANCE WITH LOCAL ELECTRICAL CODES AND STANDARDS.

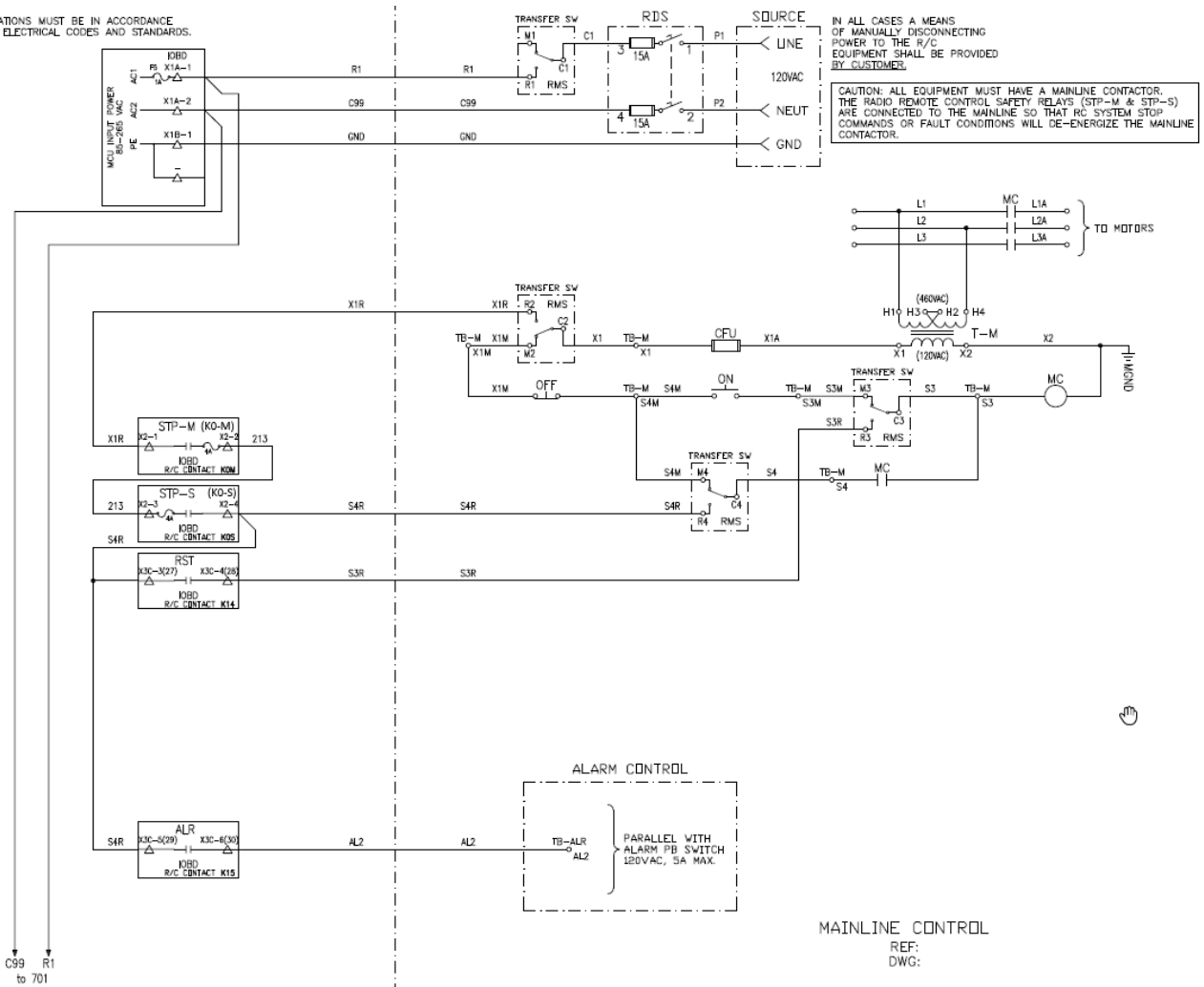

Figure 21 Example Typical non-PLd Mainline and Manual Remote Transfer Drawing

The diagram above is provided as a typical example of many machines and most older designs, this is not compliant however with a PLd level design because on the radio side the two safety relays K0-M and K0-S are wired in series and on the machine side there is a single channel design that could be subject to a single component fault, specifically the MC could mechanically fail ON, and prevent power disconnection.



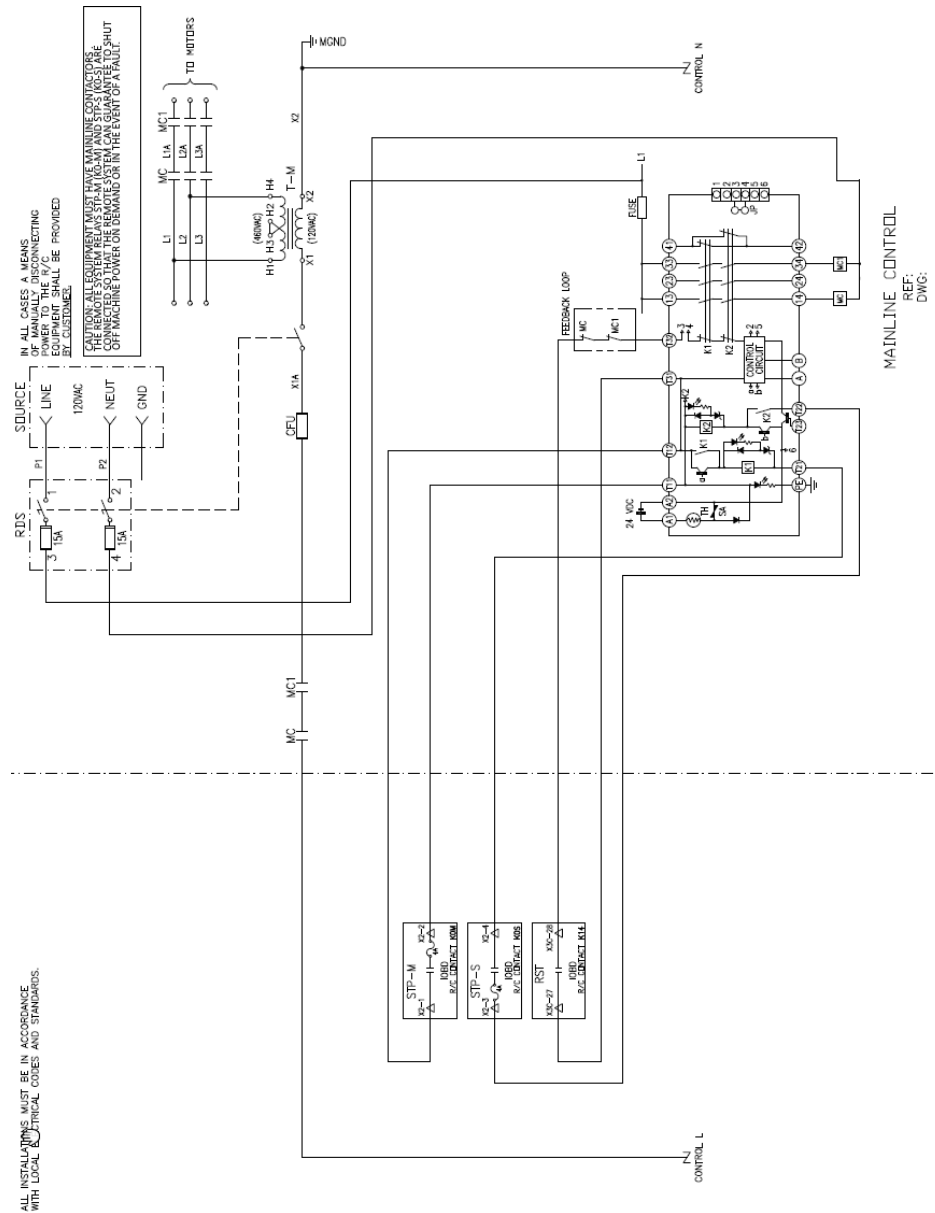

Figure 22 Example PLd Mainline using typical Safety relay for MC diagnostics

The diagram above is provided as an example of a PLd level design for the control of redundant mainline contactors.

On the radio side the two safety relays STP-M (K0-M) and STP-S (K0-S) are wired separately to two independent control channels of a safety relay and the reset output RST is wired in series with two normally closed contacts from MC and MC1 that would prevent a reset in the event of a failed ON MC contactor.

The Safety relay then controls MC and MC1.

This is a simple way to implement diagnostic coverage of MC and MC1.

The fundamental design can be implemented without a safety relay but care needs to be taken to ensure that a reset is actually possible.



	WARNING
	ALL EQUIPMENT MUST HAVE ONE OR MORE MAINLINE (ML) CONTACTORS INSTALLED AND ALL MOBILE EQUIPMENT (E.G., CRANES) MUST HAVE A BRAKE INSTALLED. THE REMOTE CONTROL SAFETY RELAYS MUST BE CONNECTED TO THE MAINLINE CIRCUIT SO THAT STOP COMMANDS WILL DE-ENERGIZE THE MAINLINE CONTACTORS AND SET THE EQUIPMENT BRAKE. FAILURE TO COMPLY WITH THE ABOVE WARNINGS MAY RESULT IN SERIOUS INJURY OR DEATH TO PERSONNEL AND DAMAGE TO EQUIPMENT.

The safety relays are energized for the first time when the MCU has power applied, the OCU is switched on, and a matching address code is sent from the OCU via a radio frequency (RF) signal to the MCU.

The safety relays must be wired to the mainline (ML) contactors.

Turning the OCU ON and completing the Start Sequence will energize the mainline contactors.

NB: the Start Sequence may include a second Reset output to close the mainline contactor.

Once the mainline is energized, a continuously repeated valid signal must be received for function outputs to engage. If this signal is interrupted for any reason, all outputs will switch off.

6.12 Manual / Remote Transfer

Changing operation back to manual may be required from time to time, this can be via a full transfer using a HAN style multi-pin connector or by a Transfer Switch. If the equipment is to be operated in the radio only mode and there are no manual controls, the transfer switch may be omitted.

The Transfer switch if used should be clearly marked as belonging to the system and close to the MCU.

If the MCU is permanently connected there must be a clearly defined and identified means of disconnection.

If there are multiple control supplies being switched by the MCU, a clearly placed warning label shall be attached to the enclosure.

Installing the transfer switch may require changes to the controlled equipment wiring. Prior to changing any existing wiring, create a wiring diagram of the planned changes. Use existing empty terminals on terminal boards as tie points.

Refer to Fig 21 above for an example wiring diagram.

When the transfer switch is in the 'REMOTE' position, the manual controls should be disconnected and all power should be transferred to the radio control relays. When the transfer switch is placed in the 'MANUAL' position, manual control of the equipment should be restored.

When switching the transfer switch between remote and manual control, observe the following precautions:

- Do not transfer control of a crane with a load lifted. Always set down all loads prior to changing the position of the transfer switch.
- If the crane is equipped with a magnet, it shall be set in the drop position prior to changing the position of the transfer switch.
- Turn OFF the OCU and temporarily remove the Battery Pack.



6.13 Main Circuit Breaker

One or more Main circuit breakers must be installed to isolate all power to the machine to enable safe maintenance operations to be carried out. The circuit breakers must be located within three meters (or as defined by local code) of the MCU.

6.14 Control Circuit Power

The control supplies connected to the MCU may come from more than one source, it is imperative that all power be isolated before commencing any installation or deinstallation work on the MCU.

	WARNING
	THE MCU MAY BE CONNECTED TO, AND SWITCHING MULTIPLE POWER SOURCES, ENSURE THAT THE MCU IS COMPLETELY ISOLATED BEFORE CONNECTING OR DISCONNECTING ANY WIRING. FAILURE TO COMPLY WITH THE ABOVE WARNINGS MAY RESULT IN SERIOUS INJURY OR DEATH TO PERSONNEL AND DAMAGE TO EQUIPMENT.

6.15 Antenna

The antenna may be internal, mounted directly to the connector on the MCU enclosure or remotely mounted via an extension cable.

A directly mounted antenna must: (1) have a clear line of sight to the operating area, (2) not be mounted within a secondary enclosure, and (3) not be mounted against any steelwork that would de-tune it.

If the antenna is remotely mounted, connect the extension co-axial cable to the connector on the MCU enclosure.

Installation rules:

7. The antenna extension (co-axial) cable is to be no longer than required, and at most 50 feet long (without further reference from your supplier).
8. Co-axial cable should be of type RG58AU or similar.
9. If the co-axial cable is connected to an antenna that is mounted on the outside of a secondary enclosure, it may be taken directly from the MCU enclosure to the secondary chassis mount connector. The co-axial cable should be mounted securely and kept away from all power carrying conductors.
10. If the co-axial cable is going to an antenna remote from the MCU location, it must be kept separate from any power carrying conductors and mounted within a metallic conduit system for protection.
11. If the MCU is mounted within a secondary enclosure, the metallic conduit should be correctly mounted with earth bonding to the secondary enclosure.
12. If the MCU enclosure is mounted directly to the crane/machine, a terminating junction box must be installed adjacent to the antenna connector with a suitable gland for the co-axial cable to exit and connect to the antenna connector on the MCU.
13. Conduit shall not be connected directly to the MCU enclosure as there is no provision for grounding it within the MCU.



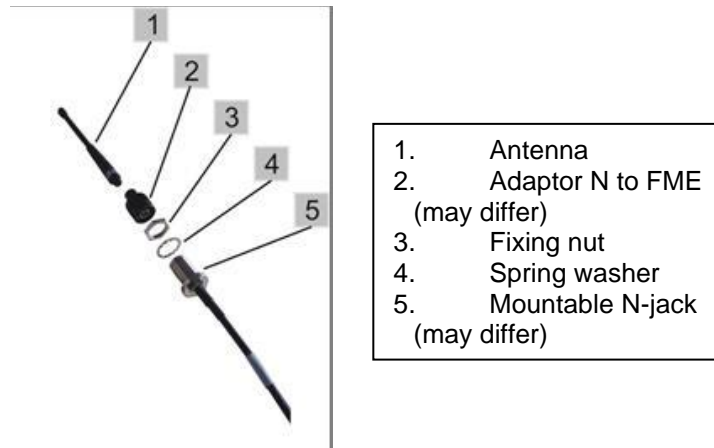



Figure 23: Remote Antenna Parts

If you have ordered an optional “remote antenna”, there will be a connector for the antenna cable at the top of receiver enclosure.

1. Install the antenna at a location from where a good visual connection to the handheld transmitter exists.
2. Fix the mountable N connector [5] (\varnothing 15 mm) using the spring washer [4] and the fixing nut [3].
3. Push and screw the N to FME adaptor [2] to the jack and screw the antenna [1] to the FME-connector.
4. Route the antenna cable to the receiver and attach it to the connector at the transmitter enclosure.

	<p>CAUTION</p> <p>Hazard of short circuits inside the housing: The antenna connector cable inside the MCU enclosure is retained within a clip next to the RF module. This ensures that if the antenna connector cable is disconnected inside the enclosure, it will not make contact with any exposed live terminals. When changing the MCU, the antenna connector cable must be passed through this clip to secure it.</p>
---	--



7. Optional System Features

The following features may be included in your system; many of these features are controlled through the OCU but impact MCU functionality.

Not all features are compatible with or available for all OCU types.

7.1 OCU Automatic Turn-Off

The OCU turns off automatically when the following events occur:

- Battery discharge protection (battery is low)
- Auto Off timeout expires (pre-set between 30 seconds to 30 minutes, or never)

7.2 System Startup Options

The way that the OCU and MCU start are relatively standard between applications are carefully controlled to provide a safe system for that application.

7.2.1 Normal Start-up

For a most applications the OCU will not start unless all functions are in the off position, and the MCU will not allow a controller with an active function to link until all active functions are released, these two factors provide protection against 'unexpected start-up'.

7.2.2 OCU Roaming

For some applications the OCU will be moved between different zones of a large machine where each zones is controlled by a different MCU each of which is connected into the machine power and where at least one of these MCUS needs to be within range of the OCU and active to prevent the machine being shut down. It may also be necessary for an active function to transfer between MCUs without having to go through the OFF position. In this case the OCU is still subject to function off at start-up testing to prove switch safety, but the MCU has its function off at linking turned off.

This allows an OCU with an active function to move seamlessly between MCUs and any MCU in range will energize the main safety relays plus the active OCU function on receipt of a valid RF signal.

7.3 Motion Enable Features

7.3.1 Push To Operate (PTO)

In a PTO enabled system, there is a means of activation that must remain depressed continuously for the motions to remain active. The actuator may take the form of a button in the end of each joystick, a bar or pad on the front of the controller, or a button on the face or side of the controller.

- Pros
 - Ensures continuous guarding; removal of pressure on the button, bar or pad cause instant cessation of motion
- Cons
 - Buttons can be hard to maintain and can cause operator fatigue
 - Bars and pads can be easier to maintain, but are difficult to implement in many controller designs



7.3.2 Push To Enable (PTE)

In a PTE system, there is a means of activation that only needs to be depressed momentarily before a lever, joystick or button is activated for the motions to operate. The enable actuator may take the form of a button in the end of each joystick, a bar or pad on the controller or most typically one or two push buttons on the face or side of the controller. After the enable button is pressed, the operator has a few seconds (this time is configurable) to start operating a motion; if this time is exceeded, the button must be pressed again. Once the motions are activated and being used they will stay active until all motions are returned to the neutral position for more than a few seconds (configurable), then the enable is required once more.

- Pros
 - Easy to use
 - Protects against accidental activation before the motion is enabled
- Cons
 - Once activated, if an additional lever is accidentally deflected, protection will require removal of the deflecting mechanism or pressing the Stop button



7.3.3 Double Jog Enable (DJE) (LRC OCUs only)

In a DJE system, the motion joystick and paddles are prevented from operating on the first deflection. This means that from an off state, any accidental deflection will not result in the motion being activated and the operation is protected.

- Activation Sequence
 - When turning on the controller, all joysticks are disabled
 - In order to enable all the joysticks, any of the joysticks must be deflected, brought back into zero and then deflected again in less than a configurable time of between 500 ms (minimum practical) and 3 seconds, in 500 ms increments; otherwise, all the joysticks remain disabled
- Operation
 - Once the joysticks are enabled, they remain enabled until all joysticks are returned to neutral for a period of time greater than a configurable period between 1 and 30 seconds (short configured times are advised)
- Indication
 - The respective status of the joysticks is indicated by a separate LED driven from two of the LED outputs to create the following sequence of colors:
 - Green: Joysticks disabled
 - Red: Joysticks enabled
 - Orange: During initial enabling sequence
- Pros
 - Easy to use
 - Protects against accidental activation before the motion is enabled
- Cons
 - Once activated, if an additional lever is accidentally deflected, protection will require removal of the deflecting mechanism or pressing the Stop button

7.3.4 Vigilance

The Vigilance function is an optional feature and is another method of maintaining the system in an active state; it is available for any LRC controller.

This method requires the operator to repeatedly activate a switch before a software timer expires.

As an example, an operator may be required to activate a toggle switch every 30 seconds or less. If the operator fails to reset the toggle switch, a warning is issued for 10 seconds. During this period the operator can still reset the vigilance function, but if this period times-out without resetting, the OCU shuts down.

The timeout time is configurable between 1 second and 11 minutes, in 1 second increments.

The warning period is configurable between 0 and 59 seconds.

Note that this feature is more closely related to machine and vehicle operation than crane use.



7.4 IR Link

7.4.1 Feature and Benefits

Cattron Excalibur, LRC-M, LRC-L and SCU32 controllers are able to use IR (Infra-Red) Link functionality.

IR Link functionality makes it possible to define one or more precise zones, in which the function of an Operator Control Unit (OCU) can be enabled. It could, for example, enable an OCU to start working, or it can change the way a controller is allowed to work based on its location and presence relative to a specific IR transmitter.

This functionality can be used to prevent unintentional system start until an operator is in a precise location, such as under a crane or by a machine, and by doing so prevent accidents that can be caused due to the following scenarios.

- An employee or visitor picks up a controller and moves the controls around, unaware that it is actually operating a crane with consequentially dangerous results.
- An employee is working on a controller in a workshop and has not isolated the crane supply; the crane moves around, causing material damage and narrowly misses causing serious injuries or death to personnel.
- An operator picks up the wrong controller, fails to verify the identity of the crane, and, while thinking it is not working, a crane behind him is moving, which hits an adjacent crane with a suspended press die that then swings into the press and is irreversibly damaged.

When a system is configured to control functionality by the presence of a specific IR transmitter, it makes it possible to automate the selection of some function or piece of equipment, eliminating manual selection errors and keeping the operator in a safe location.

All these features improve efficiency, enhance safety, and prevent damage to materials and personnel, and so improve productivity.

7.4.2 Features Options

The features that are made possible with the Infra-Red Link are:

- Infra-Red Close Start – requires an OCU to visit a zone before operation becomes possible
- Infra-Red Function Enable – requires an OCU to stay in a zone to continue operating
- Infra-Red Zone Control – passes positional information to the OCU that is then sent to the MCU

These features require one or more Infra-Red (IR) transmitters on the machine and an IR sensor that is built into the OCU.

The LRC-M, LRC-L and SCU32 are able to use all features; the Excalibur is able to use Close Start and Function Enable.



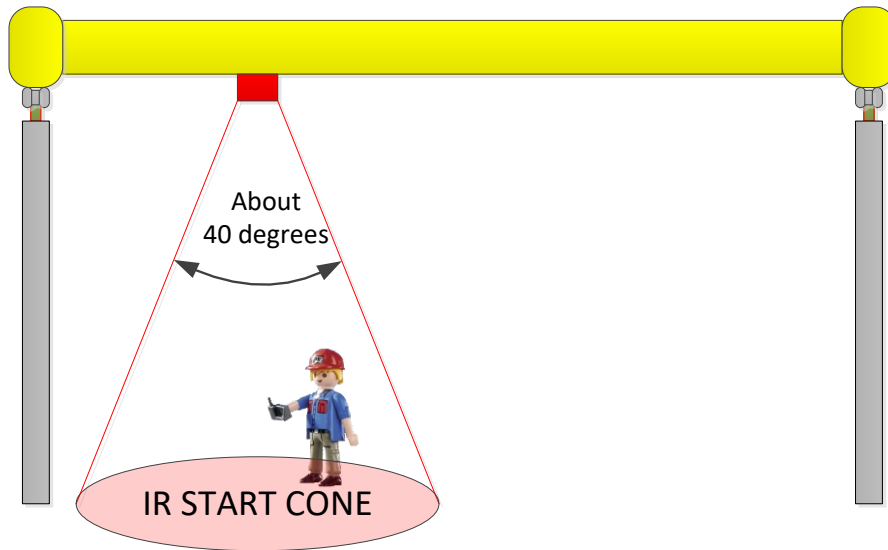

Figure 24: IR Close Start

Note: The controller will only start when inside the IR zone.

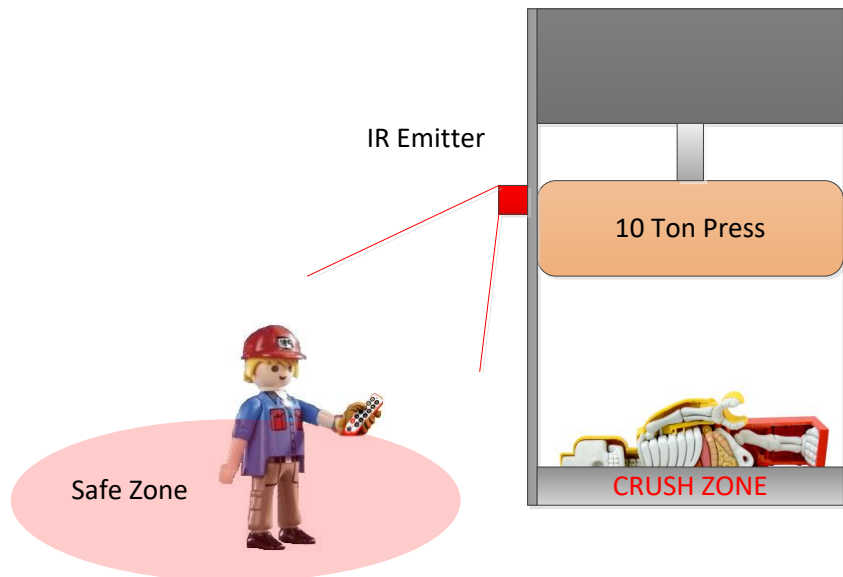

Figure 25: IR Function Enable

Note: The controller only operates the machine when it is inside the IR zone.



7.4.2.1 IR Zone Control

This mode is compatible with the LRC-M, LRC-L and SCU32 OCUs.

In this mode, the OCU takes information from the IR zone it is in and relays that to the MCU; the MCU therefore knows specifically where the OCU is and selection is automatic. This makes it possible for a single MCU to safely control multiple devices based on the specific location of the associated OCU, with no possibility of manual error.

In the image below, for example, it would make it possible for a single MCU to understand an OPEN/CLOSE command to control the correct furnace door based on the differing 8-bit data.

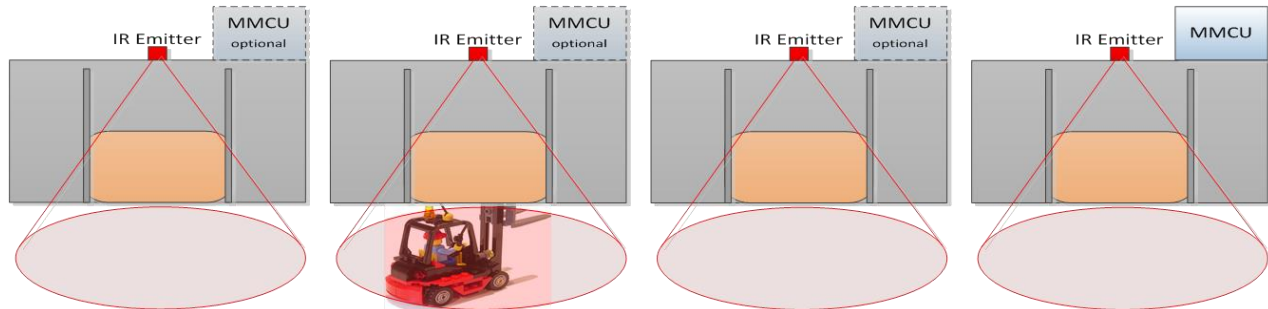

Figure 26: IR Zone Control

7.5 RF Range Control

7.5.1 Feature and Benefits

RF Range Control provides features that can be used in many different ways to enhance safety and prevent accidents. It enables a user to impose limits on the distance between the OCU and the machine at startup and during operation. This prevents unintentional system start and having an operator at an excessive distance from the machine. These features prevent accidents like those in the following scenarios.

- An employee or visitor picks up a controller and moves the controls around, unaware that it is actually operating a crane with consequentially dangerous results.
- An employee is working on a controller in a workshop and has not isolated the crane supply; the crane moves around, causing material damage and narrowly misses causing serious injuries or death to personnel.
- An operator picks up the wrong controller, fails to verify the identity of the crane, and, while thinking it is not working, a crane behind him is moving, which hits an adjacent crane with a suspended press die that then swings into the press and is irreversibly damaged.

Range Control is considered to be a safety critical feature by many prestigious industrial users in industries such as metals manufacturing, vehicle production, aircraft maintenance and power generation. This is in part because it is clearly safer, and in part because it can be considered as recommended in European Standard **EN 60204-32** (Safety of machinery – Electrical equipment of machines – Part 32: Requirements for hoisting machines). Section 9.2.7 has a clause that states '*Where necessary, means shall be provided so that the hoisting machine can only be controlled from operator control stations in one or more predetermined zones or locations*'. RF and IR controlled range features make it possible to meet this requirement where it is necessary to do so.



7.5.2 Feature Options

There are three Range Control options:

- Close Start - requires the operator to approach the machine before start is possible (*antenna diversity is optional*)
- Range Limit – limits the maximum operating range (*requires antenna diversity*)
- Range Minimum - limits the minimum operating range
- Range Control is available for either 433-434 MHz or 450-470 MHz using the LRM transceiver.
- It may use a single antenna to implement the Close Start option, but the use of dual antennas can provide multiple Close Start locations.
- The use of dual antennas is required to improve precision when using the Range Limit or Range Minimum options.
- A one-time system calibration is required; this can be made via a serial adapter directly attached to the MCU. Alternatively system calibration may be carried out on the ground with a laptop computer via a long range **Bluetooth®** wireless technology link that is temporarily connected to the MCU. A Class 1 Bluetooth Dongle may also need to be fitted to the PC to increase the range beyond that which is built in to the Bluetooth device.

7.5.3 Operating Modes

There are three operating modes as described below. It is possible to select only a single mode or a combination of Close Start and Range Limit, or Range Limit and Range Minimum, but not Close Start and Range Minimum.

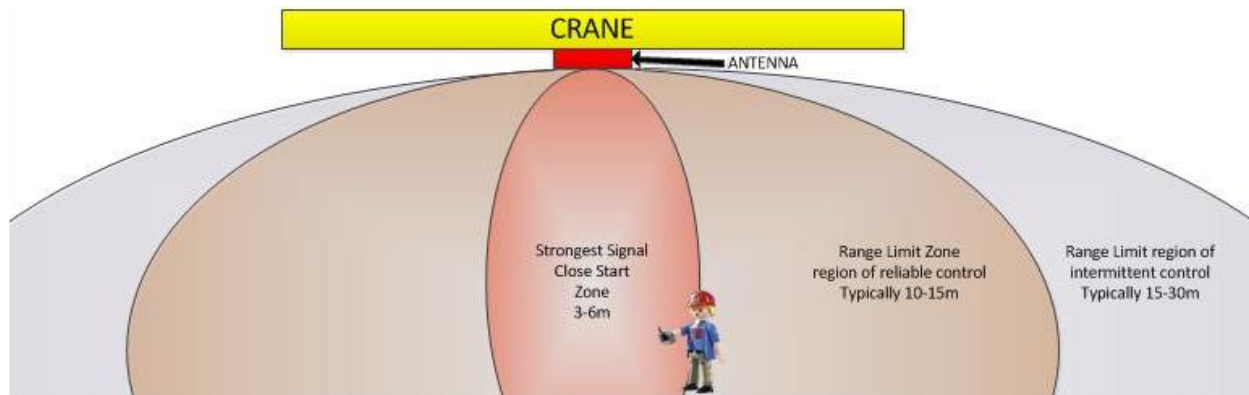

Figure 27: Signal Strength Decreases as Distance Increases

7.5.3.1 Close Start

Close Start (CS) is the primary mode that both enforces security and can be set up with a good level of precision. When set, it requires an operator to approach the crane or machine before it is possible to reset the remote and gain control of the machine. Typically, the close start range would be set to about 6 m (20 ft) maximum. This zone is set as an unreliable zone, meaning that it might require the operator to move around a little in the CS zone before it is possible to gain control. This will only take a few seconds and is not a problem before operation has commenced.



CS is possible with only a single antenna, but where a crane passes over large machinery, it may be necessary to have two antennas, so that at least one antenna has direct sight of a convenient and potentially safer operating area; otherwise, it might not be possible to gain control of the crane.

7.5.3.2 Range Limit

Range Limit (RL) imposes some restrictions on the maximum distance that an operator may be from a machine before operation is stopped. This distance has to be a reliable operating zone where the RL will not interrupt normal use.

A typical RL reliable range would be about 15 m (50 ft). This by implication means that intermittent operation may be possible at 30 m (100 ft). If the pre-set RSS is exceeded for a preset time, the operation will be brought to a stop and the operator would have to move into a reliable RL region to regain control, or, if CS is enabled, would have to reinitiate a CS before operation could resume. RL does not work well on cranes over 10 m (32 ft) in height. RL also requires antenna diversity; two antennas are needed due to the need for increased precision.

7.5.4 Notes on the Differences between IR and RF Close Start

These range control features, and in particular Close Start, are possible using RF as described here or Infra-Red. There are some notable differences between RF and IR and hence the RF and IR Range Control features differ in the following ways:

- IR requires the addition of one or more IR transmitters and receivers on the machine and the OCU; RF uses the radios already being used for the data transmission so it is inherently simpler and may cost less.
- RF is not directional, but IR is very directional and requires the OCU to be well aligned with a clear line of sight before a CS is possible, while RF only requires a general alignment.
- IR has a relatively short range, which is good for Close Start and Zone Control; RF has a relatively long range making Close Start and Range Limit possible.
- IR may be blocked by some light sources such as welding; RF will not.

7.6 Delayed Shutoff (LRC OCUs only)

The Delayed Shutoff function is an optional feature.

Delayed Shutoff enables a controlled OCU shutdown mode that allows a user to switch from remote operating mode to a local operating mode, without the machine going into a shutdown.

For example, this allows a diesel engine driven hydraulic machine to continue to run for this short transfer period rather than the operator going through a machine/engine start sequence to get it back into manual mode. This is typically required when the OCU is left in a storage location remote from the vehicle cab; one example may be underground mining machines.

In this mode, an OCU remains active for a predefined time delay between 30 seconds and 5 minutes after the ON/OFF switch turns off. During this “DSO period”, all OCU controls are disabled except for the STOP and TILT functions.

The OCU turns off when one of the following events is true:

- The DSO period expires
- The STOP button is pressed
- A TILT event occurs (if configured)



7.7 User Authorization

The User Authorization feature is an option for LRC-M and LRC-L OCUs.

This feature requires the system to be enabled by the insertion of an ID card into a receptacle on the OCU. This receptacle reads the card and compares the ID card to a list of predefined users. If the card is current, the OCU sends a signal to the MCU that the user is authorized and enables control.

7.8 Multi Address Capability (MAC)

MAC is an optional feature and allows up to 15 MCUs to be controlled by up to seven OCUs.

Some simple examples are below; each MCU is equipped with a number of lights outputs to indicate the current status.

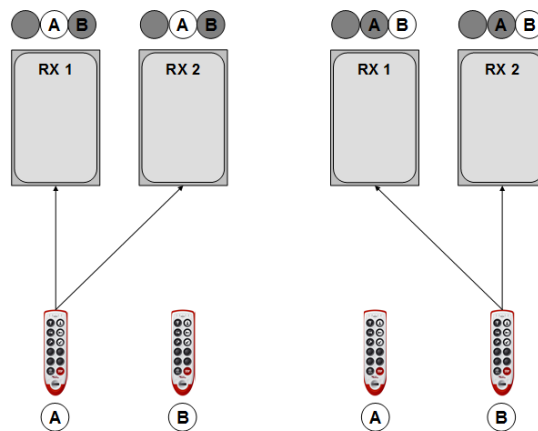

Figure 28: Multi Control Mode

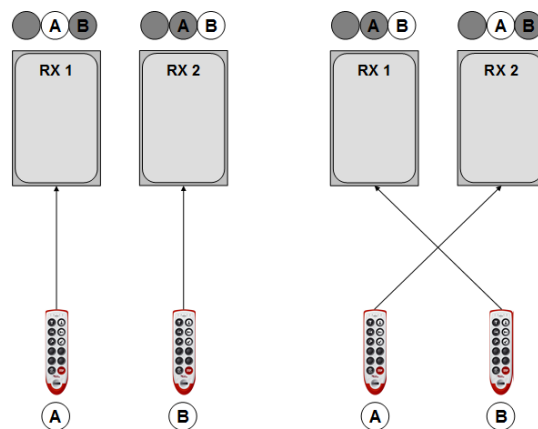

Figure 29: Single Control Mode



7.8.1 REQUEST Function

MCUs are requested by an OCU. This is performed using a separate Request button in conjunction with the position of an MCU selection on the OCU. The selection can be linked to one or more MCUs.

LRC OCUs have a rotary MCU selection switch.

All of the MCUs assigned to a selected switch position are always requested together.

MCUs assigned to an OCU as a result of a request remain permanently assigned to that OCU until released. Additional MCUs may be requested by that OCU. Selected MCUs cannot be accessed by other OCUs.

Once one or more MCUs are requested, it is possible to switch between the various available combinations of MCUs by altering the selection on the OCU.

7.8.2 RELEASE Function

The Release button is used to release the MCU(s) currently selected by an OCU.

An OCU can only release MCUs which it has previously requested. Conversely, MCUs not assigned to a specific OCU cannot be released by that OCU.

One or multiple MCUs can be released at the same time. The MCU can be set to automatically release.

7.9 Sub Address Capability

This optional feature is available for the LRC-L OCU and the MMCU4 or CT24 MCUs.

It allows one LRC OCU to have secure and simultaneous selection of up to four from a larger number of MCUs by the insertion into the OCU of a number of RFID keys.

With this feature, there is no possibility that any two OCUs can attempt to select the same MCU at the same time.

An example of use is the sequential selection of MCUs in a process flow. Keys 1 and 2 might represent hoist units 1 and 2; Keys 3 and 4 may represent sequential bridges; and the spare keys may represent further sequential bridges.

Each of the selected MCUs can be enabled or disabled by an associated toggle switch.

There are three versions of SAC defined in the following ways:

- One OCU may select 4 out of 512 MCUs
- One OCU may select 3 out of 4096 MCUs
- One OCU may select 2 out of 262,144 MCUs

7.9.1 T-SAC TransKeys

The identities of the selected MCUs are input by a secure, red RF TransKey inserted into a dual holder on the left and right faces of the OCU. An OCU has the option of two or four slots and either two or four associated toggle switches.

Two storage slots on the rail can hold unused keys.

7.9.2 B-SAC

Optionally, it is possible to use digital inputs in the OCU to select up to eight MCUs.



7.10 TDMA

TDMA is an optional feature that allows many systems to operate on the same frequency, either to minimize the number of RF licenses required on a large site or to make it possible to implement a system that requires many OCUs to be on the same frequency at the same time.

It is possible to have MCUs use both TDMA and frequency scanning when implementing a large or complex system comprising many MCUs.

As more TDMA slots allocate to a frequency, the system response to a switch change becomes slower, so a balance between allocated TDMA slots and required response is required.

7.11 Frequency Scanning

Frequency Scanning is an optional feature that allows one MCU to scan multiple frequencies (the current limit is 12). This feature allows one MCU to operate from any one out of many different OCUs transmitting on different frequencies.

Frequency scanning may be combined with TDMA, and MAC or SAC.

This feature is likely to be used where TDMA is not needed, or where the number of OCUs on air exceeds the TDMA allocation per frequency.

This feature is available on all MCUs.

For example, an MCU running frequency scanning of eight frequencies, each running with OCUs running TDMA with seven slots, could seek and lock onto a valid address from 56 (= 8 X 7) OCUs.

7.12 SymmetryLock™

Tandem operation is required when lifting large and heavy objects that are too large for a single crane; the wing of an aircraft or the carriage of a rail car are both good examples. If the cranes being used do not move together in symmetry, there is a risk of the load being dropped with consequential damaging to the load, surrounding equipment and personnel.

Traditionally, tandem crane operations have required additional systems to be fitted to form a safety interlock between the cranes involved. This requires additional hardware, installation and maintenance, all adding to cost and complexity.

SymmetryLock™ protects multiple cranes being used in tandem by a single remote control operator.

SymmetryLock™ is integrated into the remote control system and utilizes multi crane wireless feedback loops to ensure that all cranes continue to move in unison; this means that no additional hardware or set-up is required.

SymmetryLock™ is able to interlock typical dual, triple or quadruple crane installations as well as dynamically changing travelling hoist/bridge combinations. It continuously maintains the interlocking with no additional user intervention required. This is fast and efficient and keeps the operation safe from RF communication or crane drive faults that might cause an unsynchronized lift.

SymmetryLock™ meets the required parts of stringent European safety standards such as EN ISO13849 PLd, EN ISO 60204-32 and EN15011, and exceeds the safety standards in many other regions.

Being able to prevent potential load drops provides many additional opportunities to protect equipment and personnel in almost any plant with tandem lifting operation.



7.12.1 Key Value Statements

- Prevents costly and dangerous accidents caused by unsynchronized lifts and loads being dropped when tandem moves are made.
- Reduces liability exposure caused by damage to equipment and personnel.

7.13 Multi-MCU Talkback

Multi-MCU Talkback enables one Operator Control Unit (OCU) to receive information back from several Machine Control Units (MCUs).

This Talkback information can be used to create safe feedback loops to each MCU that are used to enforce safe control over tandem lifting with SymmetryLock™.

This Talkback information can also be used to display status and information from multiple MCUs, on the OCUs LCD in the form of Text or Graphics, activate the LCD Backlight, control the status LEDs, activate Haptic (Vibration) or audible alerts, etc.

The information could be obtained from many different types of devices, such as:

- Load Scales
- Positional Sensors
- Overload Sensors
- Confirmation of State
- Warning State
- Process Data
- Instructions for operators

7.14 Talkback and LCD Display Resolution

Talkback is an optional feature.

Talkback may be directed to LEDs, the buzzer, and (if fitted) the LCD display and backlighting as well.

For LRC-M and LRC-L OCUs fitted with the optional LCD display, this display has a resolution of 128 x 64 pixels and is divided into eight lines. The first and last lines are reserved for system status messages, and the remaining six lines may be used by the user for Talkback information as text, graphics, or both.

Customers have the option of having the Talkback configured for them, or the flexibility of a tool to be able to program and customize the Talkback themselves.



8. Requirements to Achieve PLd within a 'System'

All CattronControl MCUs meet a PLd rating for the Operate (main contactor control safety relays), these are force guided contact safety relays, monitored by both master and slave processors.

Additionally, all function relays are designed to meet a PLd safety level to the point of the relay driver circuits, i.e. both the high and low side relay coil drivers are independently driven and monitored (with master and slave processors) but contact state is excluded. These relays achieve CAT2 PLd (BUT contact state is excluded, based on mission time being a tiny fraction of the relay expected time to dangerous failure)

In the CT24-9-ASO MCU and certain configurations of the MMCU4 MCU, some functions also use safety relays and monitoring is extended to the relay contact state meaning there are no possible hidden error states that would not result in the Operate relays being turned off, these meet CAT 2 PLd.

If a user wants a CAT3 PLd function, using two of these ASO function relays will achieve that.

When using either the MMCU4 or the CT24-9-ASO it has to be remembered that the MCU is only one part of a 'System', the system will include the associated OCU and the machine to which they are integrated; to achieve an overall PLd rating (if required) no part of that serial system or configuration can be below a PLd rating.

The machine itself is outside of the scope of this user manual but the corresponding OCU is not; this MCU can be used with any of the CattronControl™ series of OCUs, each of which meets a PLd level for their machine Stop function and can also meet a PLd for their control functions provided the specific control element (switch) is configured as a dual channel (Category 3) architecture.

e.g. An Excalibur or MKU OCU, configured so that both the direction switch and speed switch are required together to activate a safety function relay in the CT24-9-ASO MCU.

(NB: the direction and speed switches also exhibit both mechanical and electrical diversity), each of course is subject to the normal OCU function OFF at switch-on testing, so by using a specific OCU configuration and an appropriate MCU type a CAT 2 or CAT 3 PLd control function is possible.



9. Functional Safety Compliance Data CT24-9-ASO

9.1 Mission Time

10 Years.

9.2 Service Time

MCU power must be reset at least annually.

9.3 MTTFd Scoring Table

Function	MTTFd Years	SCORE
STOP	723	HIGH
ASO Relay	162	HIGH
Non-ASO Relay	110	HIGH

9.4 Diagnostic Coverage (DC) Scoring Table

Function	%	SCORE
STOP	97	MEDIUM
ASO Relay	96	MEDIUM
NON ASO Relay	91	MEDIUM

9.5 CC Failure

A Minimum score of 65% is required, this device achieves 80% and meets requirement.

9.6 B10d Values Used

The following values were used in the calculations of MTTFd;

STOP Safety relay

1M ops electrical life safe failure because output will be OFF

50 million ops mechanical and dangerous failure because output could be ON;

10 Activations a day, 300 days a year = 16,666 years

ASO safety relay

1M ops electrical life safe failure because output will be OFF

50 million ops mechanical and dangerous failure because output could be ON;

1 Activations per minute for 12 hours a day, 300 days a year = 231 years



NON-ASO Function relay

- 1M ops electrical life safe failure because output will be OFF
- 30 million ops mechanical and dangerous failure because output could be ON;
- 1 Activations per minute for 12 hours a day, 300 days a year = 138 years

9.7 SRP/CS Performance Levels

All MCU SRP/CS meet the requirements of EN13849 performance level d as follows

Stop Function

Cat 3 PLd

ASO Relay functions

Cat 2 PLd

Category 3 to safety relay drivers and CAT 2 contact state monitor, dangerous state will be detected.

Category 3 output configuration is possible if two ASO relays are used for a single function.

Non ASO Relay functions

Cat 2 PLd

Category 3 to relay drivers (**contact state excluded**)

Contact State Exclusion based on likelihood of contact welding closed when installed correctly being extremely remote and the MCU service life of 10 years being 10% of the expected life to mechanical failure.

9.8 Equipment PL Summary

Function	Exclusions	MTTFd	MTTFd Rating	Dcavg	Dcavg Rating	Cat	PLlow	CCF	Meets Minimum Requirement of PL d	PFHd
STOP	NO	723	HIGH	97	MEDIUM	3	d	YES	YES	4.29E-08
ASO Relay	NO	162	HIGH	98	MEDIUM	2	d	YES	YES	2.29E-07
Non-ASO Relay	YES	110	HIGH	91	MEDIUM	2	d	YES	YES	2.29E-07

PFHd from Table K1 of EN ISO 13849-1 (MTTFd capped at 100 years)



10. MCU Error Codes

ERROR CODE	ERROR	ACTION
2 flashes	Transkey cannot be read	Make sure the Transkey is in place
3 flashes	Transkey configuration fault	Verify Transkey configuration is coherent with the actual hardware; for example, module selected is not the same as the one installed
4 flashes	Fault during voltage monitor test	Send to Cattron for repair
5 flashes	Fault with the safety relays	Send to Cattron for repair
6 flashes	(not used)	
7 flashes	Fault with RF module	Replace the RF module
8 flashes	General system error	Send to Cattron for repair
9 flashes	Relay control voltage is too low	Send to Cattron for repair
10 flashes	Hardware fault	Send to Cattron for repair
11-12 flashes	(not used)	
13 flashes	Slave CAN controller cross-monitor error	Make sure both master and slave CAN interfaces are properly connected to the CAN bus
14 flashes	Master CAN controller cross-monitor error	Make sure both master and slave CAN interfaces are properly connected to the CAN bus
14 flashes	Rotary switches invalid setting	Make sure switches SW1 to SW3 are set to valid positions



11. CE Declaration of Conformity

Hereby Cattron declares that the radio equipment is in compliance with Directive 2014/53/EU. View the EU Declaration of Conformity document. www.cattron.com



12. Technical Specifications

TECHNICAL DATA AND SPECIFICATIONS

ELECTRONIC DATA		MECHANICAL DATA	
Commands	9, 17 or 32 relays + 2 safety Stop relays	Dimensions/weight	
Digital circuitry	Dual-processor technology	CT24-09-ASO	150 x 170 x 105 mm 1.05 kg (5.9 x 6.7 x 4.2 inches) (2.3 lbs)
System addresses	24 bits = 16 million addresses	CT24-17	235 x 170 x 105 mm 1.50 kg (9.3 x 6.7 x 4.3 inches) (3.3 lbs)
Hamming distance	d=6 (Telegram verification)	CT 24-32	310 x 170 x 105 mm 2.5 kg (12.2 x 6.7 x 4.2 inches) (5.5 lbs)
Supply voltage	42, 48, 110-240VAC 50-60Hz 1A (nominal voltage) 12/24 V DC (optional)	Housing material	High Impact polystyrene (HIPS)
Power consumption	15 VA	Housing protection rating	IP65
OPERATION AND INDICATION		Operating temperature	-20 to +60 C (-4 to +140 F)
CT24-09-ASO	4 safety command relays 5 standard command relays (7NO + 2 CO) + Stop	Storage temperature	-40 to +70 C (-4 to +155 F)
CT24-17	17 command relays (15 NO + 2 CO) + 2 Stop	Vibration and shock	Vibration/impact and shock tested
CT 24-32	32 command relays (28 NO + 4 CO) + 2 Stop	Altitude	<5000m
Relays	5A 250V AC 30VDC	Relative Humidity	<70% non-condensing
Transkey™	System configuration, address and RF channel setting	RADIO FREQUENCY	
LED	5 multi-function LEDs	Frequency range	335 MHz 406-419 MHz 433-434 MHz 447-473 MHz 869 MHz 902-927 MHz other frequencies possible
ACCESSORIES		Regulatory	Licensed and unlicensed bands available
Interface connection	2 cable glands (standard) Han24, Han32, Han64 (optional)	RF Security	Black Channel
Antenna	Optional external antenna and line kit	RF channel spacing	12.5 kHz; 25 kHz and others
		Antenna	Internal or external



Due to continuous product improvement, the information provided in this document is subject to change without notice.

Cattron Support

For remote and communication control systems support, parts and repair, or technical support, visit us online at:
www.cattron.com/contact

Cattron North America Inc., 655 N River Rd NW, Suite A, Warren, OH 44483